

Model 408 NO Calibration Source™



The Model 408 Nitric Oxide Calibration Source™ is a portable source of nitric oxide that allows one to calibrate any nitric oxide monitor. The instrument scrubs NO from ambient air and produces either zero air or air having a mixing ratio of NO in the range 10-1,000 parts-per-billion by volume (ppbv). The desired NO concentration is chosen from the easy-to-use menu using a rotary select switch. The instrument can be programmed to output up to 10 individual NO step concentrations over a chosen time interval. The total output volumetric flow rate is 3.0 L/min, and the NO mixing ratio is controlled so as to be independent of ambient temperature, pressure and humidity.

You can attach the NO Calibration Source™ output directly to the inlet of any nitric oxide monitor (providing that its sampling rate is less than 3.0 L/min), with the excess flow vented through an external overflow tee. Besides portability, an important advantage of the Model NO Calibration Source™ is that it provides a known concentration of NO in ambient air containing the same level of humidity as the air sample to be measured.

The NO Calibration Source™ is factory calibrated against a NIST-traceable standard. However, the calibration parameters may be changed in the menu in case the user wants to recalibrate the NO Calibration Source™ against a separately maintained standard; i.e., the NO Calibration Source™ can be used as a transfer standard. The NO Calibration Source™ may

be used, for example, for maintaining the calibration of a large number of NO monitors in the field relative to a highly stable laboratory standard. In this case, a huge advantage of the NO Calibration Source™ is its portability.

Theory of Operation

The Nitric Oxide Calibration Source™ makes use of a low pressure mercury lamp to photolyze nitrous oxide (N₂O) and produce NO in a patent-pending process. The vacuum UV emission lines of mercury near 185 nm are absorbed by N₂O to produce electronically excited oxygen atoms, O (¹D₂). A large fraction of these highly energetic oxygen atoms react with N₂O to form NO:

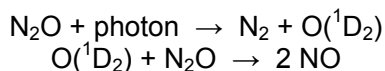

Other reactions produce a small amount of molecular nitrogen and oxygen as well. The concentration of NO produced in a flowing stream of air depends on the intensity of the photolysis lamp, the concentration of N₂O (determined by pressure and temperature), and the residence time in the photolysis cell (determined by volumetric flow rate and cell volume). By holding these parameters constant, it is possible to produce a flow of air containing a constant concentration of NO, and the concentration of NO produced can be varied most conveniently by varying the lamp intensity. Figure 1 is a schematic diagram of the NO Calibration Source™.

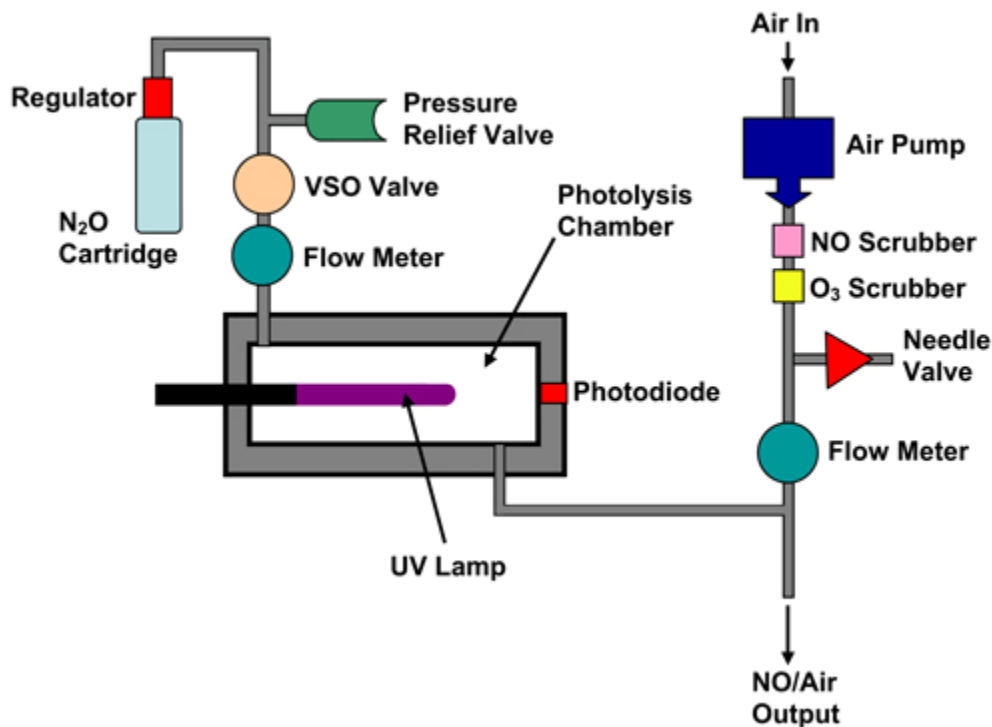

Fig. 1. Schematic diagram of the NO Calibration Source™.

An air pump forces ambient air through NO and ozone scrubbers to remove any ambient NO and ozone. The air flow rate is controlled by use of restrictors (not shown) and a needle valve that vents part of the flow and is measured by a flow meter. The needle valve is adjusted to produce a total output volumetric flow rate of ~3.0 L/min, as measured by the flow meter. Nitrous oxide is supplied by a cartridge containing liquid N₂O with a headspace pressure of ~50 atmospheres. The internal pressure is dropped by a combined cracker/regulator and additional flow restrictor, which also is used to provide coarse adjustment of the flow rate of N₂O to be in the range 60 ± 10 cc/min. A pressure relief valve inside the instrument housing prevents over pressurization by opening to the atmosphere if the pressure exceeds 25 psig. A Voltage Sensitive Orifice (VSO) valve is used to provide fine control of the N₂O flow rate to ~60 ± 1 cc/min. Within the photolysis chamber, a very small fraction of the N₂O is converted to NO and N₂ by absorption of light at wavelengths near 185 nm. Measurements of the output of the photolysis chamber show that no significant concentration of NO₂ is produced. The lamp intensity at 254 nm is monitored by a photodiode and controlled by the microprocessor. The photodiode voltage is calibrated against the output NO concentration. Pressure within the gas stream is measured but not controlled. Instead, the lamp intensity is varied to compensate for changes in pressure and total flow rate using a proprietary algorithm. Air containing nitric oxide at a selected concentration in the range 0-1,000 parts-per-billion by volume exits the instrument.

Specifications

Method for Producing NO	Photolysis of N ₂ O at 185 nm
Output Concentration	0 and 10-1,000 ppb
Precision and Accuracy of NO Output	Greater of 3 ppbv or 3% of reading
Operating Temperature Range	0 to 40 °C
Total Output Flow Rate	3 Liter/min
Rise Time	< 30 s to reach 95% of selected concentration
Operating Temperature Range	Greater of 3 ppb or 3% of reading
Diagnostic Data Output	RS232
Power Requirements	12 V dc or 120/240 V ac, 21 watt
Size	3.7 x 8.5 x 9.5 in (9.4 x 21.6 x 24.1 cm)
Weight	5.2 lb (2.4 kg)

System Includes

- Model 408 Nitric Oxide Calibration Source
- AC Power Adapter (100-240 VAC to 12 VDC) with Country-Specific Plug
- Connecting Tube with Overflow Tee
- Cigarette Lighter Adapter
- Battery Wire Connector
- Operation Manual on CD
- Calibration Data and NIST-Traceable Calibration Certificate
- Instrument Birth Certificate
- One Year Warranty

To download a brochure describing the Model 408 NO Calibration Source™ (PDF format), click on the download button below.