

# Ozone Monitor

**2B** *Technologies, Inc.*

## OPERATION MANUAL

**Model 202**

© Copyright 2001-2005, 2B Technologies, Inc.  
All rights reserved.

# **TABLE OF CONTENTS**

<i>IDENTIFICATION RECORDS</i>	iii
<i>PRINTING HISTORY</i>	iv
<i>WARRANTY STATEMENT</i>	v
<i>WARNINGS</i>	vi
<i>OZONE MONITOR INTRODUCTION</i>	1
<i>SPECIFICATIONS</i>	4
<i>OPERATION</i>	5
<i>MAINTENANCE/TROUBLESHOOTING</i>	20
<i>PARTS LIST</i>	28

## **IDENTIFICATION RECORDS**

Record the following information for future reference:

Unit serial number: \_\_\_\_\_

Warranty start date: \_\_\_\_\_  
(date of receipt)

## **PRINTING HISTORY**

New editions are complete revisions of the manual and incorporate all previous update pages and write-in instructions. This manual will be revised as necessary. Revisions can be in the form of new editions, update pages, or write-in instructions.

Revision C .....October 2005

## **TRADEMARKS & PATENTS**

2B Technologies™, 2B Tech™, 2B™ and Ozone Monitor™ are trademarks of 2B Technologies, Inc.

## **CONFIDENTIALITY**

The information contained in this manual may be confidential and proprietary, and is the property of 2B Technologies, Inc. Information disclosed herein shall not be used to manufacture, construct, or otherwise reproduce the goods disclosed herein. The information disclosed herein shall not be disclosed to others or made public in any manner without the expressed written consent of 2B Technologies, Inc.

© Copyright 2000, 2B Technologies, Inc.  
All rights reserved.

## **WARRANTY STATEMENT**

2B Technologies, Inc. warrants its products against defects in materials and workmanship. 2B Technologies will, at its option, repair or replace products which prove to be defective. The warranty set forth is exclusive and no other warranty, whether written or oral, is expressed or implied. 2B Technologies specifically disclaims the implied warranties of merchantability and fitness for a particular purpose.

### **Warranty Periods**

The warranty period is one (1) year from date of receipt by the purchaser, but in no event more than thirteen (13) months from original invoice date from 2B Technologies, Inc.

### **Warranty Service**

Warranty Service is provided to customers through phone support, Monday - Friday, from 9:00 a.m. to 5:00 p.m., Mountain Time USA. Phone support is for troubleshooting and determination of parts to be shipped from 2B Technologies to the customer in order to return the product to operation within stated specifications. If phone support is not efficient and effective, the product may be returned to 2B Technologies for repair or replacement. Prior to returning the product, a Repair Authorization Number (RA) must be obtained from the 2B Technologies Service Department.

### **Shipping**

2B Technologies will pay freight charges for replacement or repaired products shipped to the customer site. Customers shall pay freight charges for all products returning to 2B Technologies.

### **Conditions**

The foregoing warranty shall not apply to defects resulting from improper or inadequate maintenance, adjustment, calibration or operation by customer. Maintenance, adjustment, calibration or operation must be performed in accordance with instructions stated in the Ozone Monitor manual. Usage of maintenance materials purchased from suppliers other than 2B Technologies will void this warranty.

### **Limitation of Remedies and Liability**

The remedies provided herein are the Customer's sole and exclusive remedies. In no event shall 2B Technologies be liable for direct, indirect, special, incidental or consequential damages (including loss of profits) whether based on contract, tort or any other legal theory. The Ozone Monitor manual is believed to be accurate at the time of publication and no responsibility is taken for any errors that may be present. In no event shall 2B Technologies be liable for incidental or consequential damages in

connection with or arising from the use of the Ozone Monitor manual and its accompanying related materials. Warranty is valid only for the country designated on the 2B Technologies quote or invoice.

## ENGLISH

 **WARNING:**  
Any operation requiring access to the inside of the equipment, could result in injury. To avoid potentially dangerous shock, disconnect from power supply before opening the equipment.

**WARNING:**  
This symbol,  on the instrument indicates that the user should refer to the manual for operating instructions.

**WARNING:**  
If this instrument is used in a manner not specified by 2B Technologies, Inc. USA, the protection provided by the instrument may be impaired.

## ESPAÑOL

 **ATENCION:**  
Cualquier operación que requiera acceso al interior del equipo, puede causar una lesión. Para evitar peligros potenciales, desconectarlo de la alimentación a red antes de abrir el equipo.

**ATENCION:**  
Este símbolo,  en el instrumento indica que el usuario debería referirse al manual para instrucciones de funcionamiento.

**ATENCION:**  
Si este instrumento se usa de una forma no especificada por 2B Technologies, Inc., USA, puede desactivarse la protección suministrada por el instrumento.

## FRANÇAIS

 **ATTENTION:**  
Chaque opération à l'intérieur de l'appareil, peut causer du préjudice. Afin d'éviter un shock qui pourrait être dangereux, déconnectez l'appareil du réseau avant de l'ouvrir.

**ATTENTION:**  
Le symbol,  indique que l'utilisateur doit consulter le manuel d'instructions.

**ATTENTION:**  
Si l'instrument n'est pas utilisé suivant les instructions de 2B Technologies, Inc., USA, les dispositions de sécurité de l'appareil ne sont plus valables.

## DEUTSCH

 **WARNHINWEIS:**  
Vor dem Öffnen des Gerätes Netzstecker ziehen!

**WARNHINWEIS:**  
Dieses,  auf dem Gerät weist darauf hin, daß der Anwender zuerst das entsprechende Kapitel in der Bedienungsanleitung lesen sollte.

**WARNHINWEIS:**  
Wenn das Gerät nicht wie durch die Firma 2B Technologies, Inc., USA, vorgeschrieben und im Handbuch beschrieben betrieben wird, können die im Gerät eingebauten Schutzvorrichtungen beeinträchtigt werden.

## ITALIANO

 **ATTENZIONE:**  
Qualsiasi intervento debba essere effettuato sullo strumento può essere potenzialmente pericoloso a causa della corrente elettrica. Il cavo di alimentazione deve essere staccato dallo strumento prima della sua apertura.

**ATTENZIONE:**  
Il simbolo,  sullo strumento avverte l'utilizzatore di consultare il Manuale di Istruzioni alla sezione specifica.

**ATTENZIONE:**  
Se questo strumento viene utilizzato in maniera non conforme alle specifiche di 2B Technologies, Inc. USA, le protezioni di cui esso è dotato potrebbero essere alterate.

## DUTCH

 **OPGELET:**  
Iedere handeling binnenin het toestel kan beschadiging veroorzaken. Om iedere mogelijk gevaarlijke shock te vermijden moet de aansluiting met het net verbroken worden, vóór het openen van het toestel.

**OPGELET:**  
Het symbool,  geeft aan dat de gebruiker de instructies in de handleiding moet raadplegen.

**OPGELET:**  
Indien het toestel niet gebruikt wordt volgens de richtlijnen van 2B Technologies, Inc., USA gelden de veiligheidsvoorzieningen niet meer.

## **1. OZONE MONITOR INTRODUCTION**

The 2B Technologies Ozone Monitor is designed to enable accurate measurements of atmospheric ozone over a wide dynamic range extending from a limit of detection of 1.5 parts-per-billion by volume (ppbv) to an upper limit of 100 parts-per-million (ppmv) based on the well established technique of absorption of ultraviolet light at 254 nm. The Ozone Monitor is light weight (4.7 lb., 2.1 kg.) and has a low power consumption ( $\approx 4$  watt) relative to conventional instruments and is therefore well suited for applications such as:

- vertical profiling using balloons, kites, remotely piloted aircraft, and other aircraft where space and weight are highly limited
- long-term monitoring at remote locations where power is highly limited
- urban arrays of ground-based detectors
- personal exposure monitoring for studies of health effects of air pollutants

### **Theory of Operation**

Absorption of UV light has long been used for measurements of atmospheric ozone with high precision and accuracy. The ozone molecule has an absorption maximum at 254 nm, coincident with the principal emission wavelength of a low-pressure mercury lamp. Fortunately, few molecules found at significant concentrations in the atmosphere absorb at this wavelength. However, interferences, such as organic compounds containing aromatic rings, can occur in highly polluted air.

Figure 1 is a schematic diagram of the ozone monitor. Ozone is measured based on the attenuation of light passing through a 15-cm long absorption cell fitted with quartz windows. A low-pressure mercury lamp is located on one side of the absorption cell, and a photodiode is located on the opposite side of the absorption cell. The photodiode has a built-in interference filter centered on 254 nm, the principal wavelength of light emitted by the mercury lamp. An air pump draws sample air into the instrument at a flow rate of approximately 1 L/min. A solenoid valve switches so as to alternately send this air directly into the absorption cell or through an ozone scrubber and then into the absorption cell. The intensity of light at the photodiode is measured in air that has passed

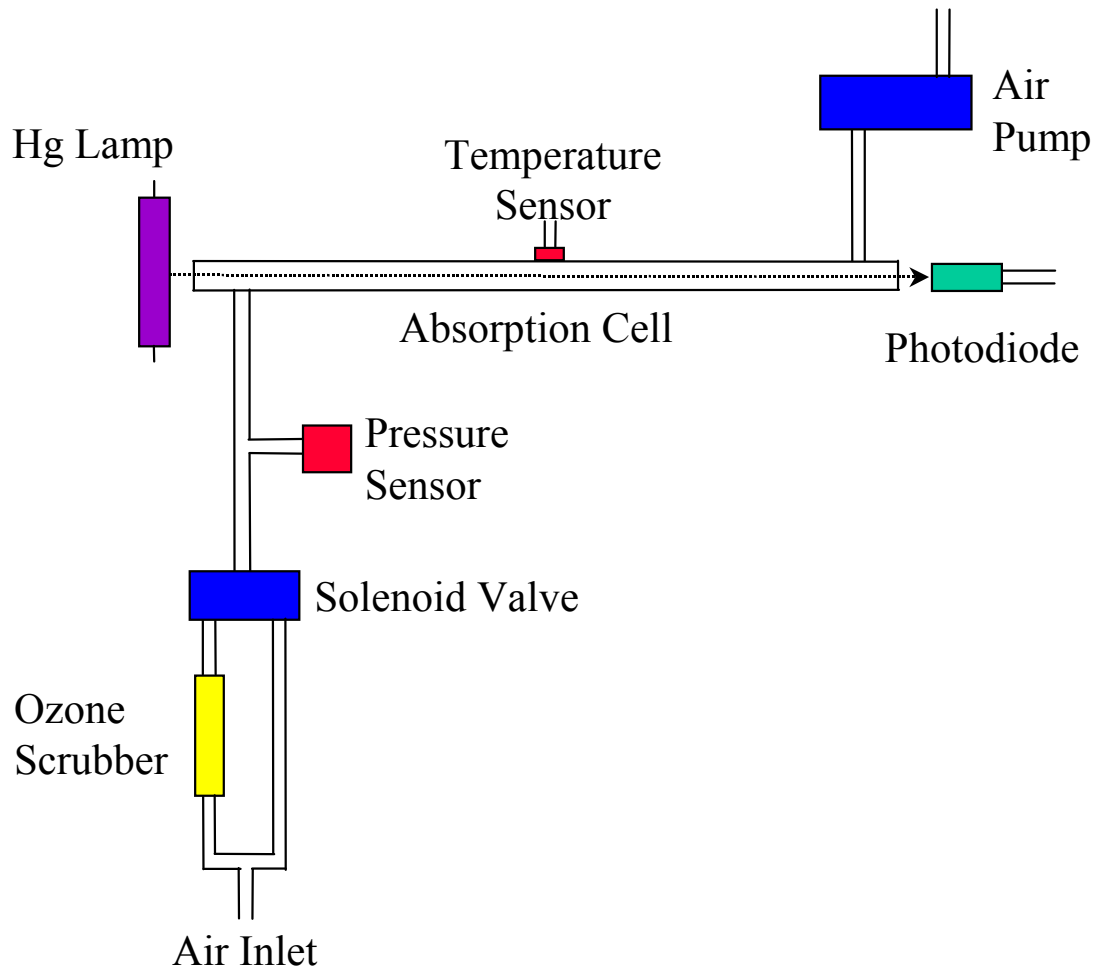

Figure 1. Schematic diagram of the ozone instrument.

through the ozone scrubber ( $I_o$ ) and air that has not passed through the scrubber ( $I$ ). Ozone concentration is calculated from the measurements of  $I_o$  and  $I$  according to the Beer-Lambert Law:

$$C_{O_3} = \frac{1}{\sigma l} \ln\left(\frac{I_o}{I}\right)$$

where  $l$  is the path length (15 cm) and  $\sigma$  is the absorption cross section for ozone at 254 nm ( $1.15 \times 10^{-17} \text{ cm}^2 \text{ molecule}^{-1}$  or  $308 \text{ atm}^{-1} \text{ cm}^{-1}$ ), which is known with an accuracy of approximately 1%. The 2B Technologies instrument uses the same absorption cross section (extinction coefficient) as used in other commercial instruments.

The logarithm of equation 1 is approximated in the microprocessor of the instrument with sufficient accuracy to provide five orders of dynamic range; ozone mixing ratios are measured up to 100 ppmv, as compared to 1 ppmv for most commercial ozone instruments.

The pressure and temperature within the absorption cell are measured so that the ozone concentration can be expressed as a mixing ratio in parts-per-billion by volume (ppbv). The instrument displays and records the cell temperature and pressure in addition to the ozone mixing ratio. The cell pressure is displayed and logged in units of either Torr or mbar and the cell temperature in units of either °C or K.

In principle, the measurement of ozone by UV absorption requires no external calibration; it is an absolute method. However, non-linearity of the photodiode response and electronics can result in a small measurement error. Therefore, each instrument is compared with a NIST-traceable standard ozone spectrophotometer in the laboratory over a wide range of ozone mixing ratios. These results are used to calibrate the Ozone Monitor with respect to an offset and slope (gain or sensitivity). The corrections for offset and slope are recorded in the instrument Birth Certificate and on a calibration sticker that can be viewed by removing the top cover of the instrument. These calibration parameters are entered into the microprocessor prior to shipment. The user may change the calibration parameters from the front panel if desired. It is recommended that the instrument be recalibrated at least once every year and preferably more frequently. The offset may drift due to temperature change or chemical contamination of the absorption cell. As discussed below, an accurate offset correction can be measured from time to time using the ozone scrubber supplied with the instrument.

## OZONE MONITOR SPECIFICATIONS

*Power Requirements* ..... 11-14 V DC, nominally 330 mA at 12 V, 4.0 watt

*Dimensions* ..... 3.5" x 8.3" x 11.6"

*Weight* ..... 4.7 lbs (2.1 kg)

*Weight with case removed* ..... 1.6 lb (0.7 kg)

*Precision* ..... higher of 1.5 ppbv or 2%

*Accuracy* ..... higher of 1.5 ppbv or 2%

---

## **2. OPERATION**

Please read all the following information before attempting to install the Ozone Monitor. For assistance, please call 2B Technologies at (303)216-1489.

**NOTE:**

**Save the shipping carton and packing materials that came with the Ozone Monitor. If the Ozone Monitor must be returned to the factory, pack it in the original carton. Any repairs as a result of damage incurred during shipping will be charged.**

### **Shipping Box Contents**

Open the shipping box and verify that it contains the following:

1. Ozone monitor
2. 110-220 V AC power adapter
3. Cigarette lighter adapter
4. Bare-wire 12 V DC battery adapter
5. Serial port cable
6. Zeroing cartridge
7. Ozone Monitor manual
8. Ozone Monitor birth certificate (inside manual)
9. Quality control data sheet and graph (inside manual)
10. Three external jacks for analog inputs

If anything is missing or obviously damaged, contact 2B Technologies immediately.

### **Operation of the Ozone Monitor**

To operate the Ozone Monitor, connect it to an external power source and turn the instrument on by flipping the front panel switch. The instrument requires a 12 V DC source which can be supplied by: 1) the 110-220 V AC power

---

adapter, 2) a cigarette lighter adapter plugged into a 12 V DC source such as found in an automobile or many light aircraft, or 3) a 12 V battery. The source can be in the range 11-14 V DC without any detrimental effects on the measurement. When using a battery, be certain to attach the positive (red) and negative (black) wires correctly. A circuit breaker and diode are installed on the circuit board in case of an electrical short or incorrect battery attachment. If activated, the breaker will reset itself after a few minutes.

Lead-acid batteries are available from numerous manufacturers in a wide range of sizes and amp-hour ratings. The larger of these, such as those for automobiles or boats, will supply power for up to several weeks. Battery packs in the correct voltage range may be constructed from nickel-cadmium (rechargeable) or lithium (light weight but not rechargeable) batteries for operation for a few hours. Battery options available through 2B Technologies may be found on our webpage: [www.twobtech.com](http://www.twobtech.com).

Once turned on, the instrument will display the version number of the software installed on the microprocessor. After a few seconds, the instrument will start displaying readings for ozone and the temperature and pressure of the absorption cell. The first dozen readings (requiring about two minutes) will be spurious, with large positive and negative swings, due to the rapid warmup of the lamp and electronics. Also, ozone readings may be inaccurate during the 10-20 minutes required for the lamp, photodiode, and internal temperature of the absorption cell to stabilize.

Inlet tubing may be attached to the ¼ inch nylon Swagelok fitting on the back of the instrument. The inlet tubing should be made of PTFE (Teflon<sup>®</sup>, PFA or some other inert material that does not destroy ozone and that does not desorb plasticizers and other organics that can contaminate the flow path. The length of tubing should be kept as short as possible (not more than a few feet) to minimize ozone destruction. Tygon<sup>®</sup>, polypropylene (which may look like teflon) and metal tubing should not be used. Teflon-lined Tygon tubing, which is used inside the instrument provides the flexibility of Tygon with the inertness of Teflon. A Teflon inlet filter is highly recommended to prevent internal contamination of the tubing and absorption cell by particulate matter. The filter should be tested for ozone loss by measuring ambient ozone with and without the filter attached. Filters and filter holders are available through 2B Technologies. See our website: [www.twobtech.com](http://www.twobtech.com).

---

If the instrument is being flown, the inlet should not point into the wind, because the resulting pressure fluctuations will result in a noisy signal. Although the instrument compensates for temperature drift, if strong temperature fluctuations are expected, as in vertical profiling applications using balloons, the instrument should be placed in a thermally insulated box.

### **Measurement of the Zero Offset**

The electronic zero of the instrument may be measured by attaching an ozone destruction cartridge to the air inlet for a period of 5-10 minutes. For an accurate measurement, the instrument must have been turned on long enough for the internal temperature to stabilize. The observed offset, which can amount to a few ppbv, can be corrected by changing this calibration parameter from the front panel, as described below.

### **Collecting Data from the Analog Output**

The data may be logged in real time using a data logger attached to the BNC analog output. The range of the analog output is 0-2.5 V. The output is scaled according to one of four sensitivities, chosen from the microprocessor menu, as described below. These are: 1 V = 200 ppbv (range of 0-500 ppbv); 1 V = 0.4 ppmv (range of 0-1 ppmv); 1 V = 4 ppmv (range of 0-10 ppmv); and 1 V = 40 ppmv (range of 0-100 ppmv). There is a small positive offset, typically 2 mV in the analog output, but this offset varies from instrument to instrument. The offset can be measured by simultaneously observing the panel display and measuring the analog output with a voltmeter.

### **Collecting Data over the Serial Port in Real Time**

To transmit data to a computer over the serial port in real time, connect the Ozone Monitor to the serial port of the computer using the 9-pin cable provided. Activate your data acquisition software; e.g., Hyperterminal (available on most Windows<sup>®</sup>-based computers) or Tera Term Pro (free download from <http://hp.vector.co.jp/authors/VA002416/teraterm.html>). The later software is preferred since Hyperterminal has a 500-line buffer limit, but the user may set the maximum buffer size for Tera Term Pro. Both programs allow you to log

---

the data to a computer file with no limit on number of data lines. Using these terminal emulation programs, data may be saved to a text file and then opened in Microsoft Excel (or other spread sheet program) where it may be converted to formatted data in columns by defining delimiters (such as commas and carriage returns) for data manipulation and graphing. The ozone mixing ratio (ppbv), internal cell temperature (K or °C), cell pressure (Torr or mbar), values of three external analog inputs in volts (if activated from the menu), date, and time are sent as comma-delimited ASCII text to the serial port (2400, 4800 or 19,200 baud; 8 bits; no parity; 1 stop bit) every ten seconds, 1 minute, 5 minutes, or 1 hour, depending on the averaging time selected from the microprocessor menu. Time is provided in 24-hour (military) format, and the date is given in European style (day/month/year).

A typical data line would read:

```
67.4,35.3,980.6,1.3876,2.3143,0.1875,15/10/01,18:31:27
```

where:

Ozone = 67.4 ppbv

Cell temperature = 35.3 °C (may be expressed in K if chosen from menu)

Cell pressure = 980.6 mbar (may be expressed in Torr if chosen from menu)

Analog input A = 1.3876 volts

Analog input B = 2.3143 volts

Analog input C = 0.1875 volts

Date = October 15, 2001

Time = 6:31:27 pm

The three external inputs are omitted from the data line if they are turned off using the menu, as described below. The analog inputs allow measurements made by other instruments to be transmitted to a computer simultaneously with those of ozone and the time and date stamp; these inputs may also be logged in the instrument's internal memory, as described below. Examples of external measurements that are commonly made along with ozone are external temperature, pressure, and relative humidity, but the outputs of any instrument may be input to the Ozone Monitor. The analog inputs may range from 0 to +2.5000 volts and are measured with an accuracy of approximately  $\pm 0.0001$  volt. An input voltage greater than +5.0 volts or less than -0.3 volts may permanently damage the instrument.

---

If the Ozone Monitor has been set to the log data mode, the output serial data line will be preceded by the log number; e.g.,

2893,67.4,35.3,980.6,1.3876,2.3143,0.1875,15/10/01,18:31:27

where 2893 is the log number.

In addition to data lines, messages are written to the serial port when logging is begun or ended, when transmission of data from the logger is begun and ended, when data collection is interrupted (e.g., due to a power failure) and when the averaging time is changed.

### **Data Averaging and Data Logging Using the Menu**

When first turned on, the instrument will start making measurements at a rate of once every 10 s. Data, along with up to three external voltages, may be logged in the internal data logger. Up to 14,336 data lines containing log number, ozone mixing ratio, internal temperature, internal pressure, date and time may be stored in internal memory, corresponding to an operational time of 1.7 days. Averaging times of 1 min, 5 min and 1 hr also may be selected from the menu, thereby allowing the instrument to operate for 1.4 weeks, 1.7 months and 1.6 years, respectively, before filling the memory. The maximum number of data lines is halved if the three analog inputs are logged along with the other data.

### **Selecting the Menu**

The menu is accessed using the Select button on the front panel of the instrument. To reach the menu, hold in the Select button until the display shows: **Menu**

Then, release the button. The panel will now display:

**Menu**  
**Dat Avg Cfg Lmp ←**

---

where **Dat**, **Avg**, **Cfg** and **Lmp** are submenus that may be selected. A blinking cursor will show across the **D** of the **Dat** submenu. The Select button may be rotated clockwise or counterclockwise to move the cursor under the first letter of one of the other submenus. To select a particular submenu, move the cursor under the first letter of a submenu and click (press in) the Select button. To exit the Main Menu and begin making measurements again, select and click on the right arrow (←).

## To Log Data

Select the **Dat** submenu from the Main Menu using the Select button. The display will now show:

**Data Menu**  
**Xmt Log End ←**

To start logging data, rotate the Select switch to move the cursor to **Log** and click to select the logging mode. You will then be asked whether you want to overwrite the data stored in the logger:

**Overwrite Data?**  
**No Yes ←**

If you select yes and start logging, all data previously stored in the logger will be irretrievably lost. If you have data in the logger that you want to keep, be sure to download it before starting logging. If you are ready to start logging, then select **Yes** by moving the cursor under **Yes** and clicking. Either selection will return you to the **Main Menu**. To start data acquisition, select ← and click.

The Ozone Monitor will then alternately display every five seconds: 1) the ozone mixing ratio and log number and 2) the ozone concentration, internal temperature and internal pressure. For example, the display might read:

**O3= 56.7 ppbv**  
**T=305.6 P=730.4**

---

where the ozone value is the most current measurement of ozone, and T and P are the cell temperature and pressure (in units of K and Torr, in this case). After 5 seconds (midway between the next 10-s measurement cycle), as an example, the display will be replaced by:

**O3= 56.7 ppbv**  
**Log= 193:0**

where **O3** is the ozone value most recently written to the logger, and the log number is 193.

If averaging has been selected, then the above display will be replaced by:

**Avg O3=56.7 ppbv**  
**Log= 193:4**

Again 193 refers to the most recent log number. The “4” in 193:4 refers to the number of 10-s data points that have been measured so far for inclusion in the next average to be displayed and logged. If 10-s averaging is used (i.e., no averaging), this number will always be 0. If 1-min averaging is used, this number will increment from 0 to 5; for 5-min averaging, the number will increment from 0 to 29; and for 1-hr averaging, it will increment from 0 to 359. This number is displayed so that the user will know how many more 10-s measurements need to be made before a new average is displayed and logged.

If there is a power failure while the instrument is in the logging mode, logging will resume after power is restored. A note of

### **Data Interrupt - Time Error < 60s**

will be written to the logger prior to writing the first new data line. In the case of a power failure, as many as 10 data lines may be lost because the microprocessor writes to the logger memory in groups of 10 lines. All data residing only in the volatile memory of the microprocessor are lost when power is interrupted. Also, the start time for logging of additional data following a power interruption will be accurate only to the nearest minute (or nearest hour when Avg = 1 hr).

---

The instrument can accommodate multiple data interruptions due to power failures. For example, one can purposely switch the instrument off, move to another location and restart logging simply by turning the instrument back on. Data sets will be separated by the data interrupt message. However, as mentioned above, start times will be accurate only to the nearest minute or hour if 1 hr averaging is chosen. If more accurate measurements of time are required, it is recommended that an external clock be used to assign an accurate time to the log number of the first data line following a purposeful power interruption. The incremental times between data lines are exact (i.e., 10 s, 1 min, 5 min and 1 hr).

**Note:** Once logging has started, you should not enter the menu, except to end logging. Entering the menu stops data acquisition, which is treated in the same way as a power failure; i.e., when logging is resumed, the start time for the new data will be accurate only to the nearest minute (nearest hour if 1-hr averaging is being used). In particular, you should not change the averaging time or turn the external inputs on or off while in the logging mode, as the earlier data stored in the logger memory will not be retrieved correctly.

### To Stop Logging Data

Hold the Select button down to obtain the **Menu**. Go to the **Dat** submenu by clicking on **Dat**. Choose and click on the **End** function. This will end data logging. You may now transmit the data to a computer by clicking on **Xmt** (see below). Alternatively, you may return to the **Menu** by clicking on ←. The stored data will reside in memory (even when new measurements are being made) and can be transmitted using the **Xmt** function as often as you like. However, all stored data are lost once logging is started again using the **Log** function. Thus, you should always transmit your data to a computer before restarting logging.

If you fail to **End** logging prior to transmitting the data using the **Xmt** function, the instrument will automatically execute the **End** function for you prior to transmitting the data.

---

## To Transmit Logged Data to a Computer Using the Serial Port

Connect the serial port of the instrument to the serial port of your computer using the cable provided. Enable a data acquisition program on the computer such as Microsoft Hyperterminal (available on most Windows® platforms) or preferably Terra Term Pro, which can be downloaded at:

<http://hp.vector.co.jp/authors/VA002416/teraterm.html>

As mentioned earlier, the disadvantage of Hyperterminal is that it has a 500 line buffer limitation.

Hold down the Select button to obtain the **Main Menu**. Go to the **Dat** submenu by clicking on **Dat**. Next, click on **Xmt**. The message “Logged Data” will be written to the serial port, followed by a carriage return and all of the lines of logged data. After all data are transmitted, the message “End Logged Data” and a carriage return are written. After transmission is complete, you can return to any position in the menu or resume ozone measurements. The logged data continues to be available for transmission until a new data log is started.

## To Average Data

Hold down the Select button to obtain the **Menu**. Select and click on **Avg** to obtain the **Avg** menu:

**Avg Menu**  
**2s 10s 1m 5m 1h ←**

Use single clicks to move the cursor to **10s**, **1m**, **5m** or **1h** for averaging times of 10 s (no averaging), 1 min, 5 min or 1 hr averaging, respectively. Then click on the averaging time you want to use. To return to the Main Menu, click on ←. To exit the Main Menu and start acquiring data, click on ← again.

While in averaging mode, the current 10-s measurement is displayed alternately with the average value, as discussed above.

---

Averaged data may be logged, thereby greatly extending the length of time that the data logger can be used.

## To Set the Calibration Parameters

The instrument is calibrated at the factory where slope and offset parameters are entered into the instrument's memory. These preset calibration parameters are given in the instrument's Birth Certificate and recorded on the calibration sticker viewable with the top cover removed. However, the calibration parameters may be changed by the user. For example, it may be desirable to provide a positive offset by a known amount (e.g., 10 ppbv) if the analog output is being used for external data logging since the analog output does not go negative below zero ppbv. Because of noise and/or an inherent offset, some measured values will be below zero at very low ozone mixing ratios or while zeroing the instrument with an external scrubber. Also, the instrument zero may drift by a few ppbv over time. For this reason, frequent zeroing of the instrument using an external ozone scrubber to determine the offset is recommended. Any change in the slope (gain) of the instrument is likely due to a serious problem such as contamination, an air leak, obstruction of air flow, or loss of catalytic activity by the internal ozone scrubber, but it also can be adjusted. Once the zero of the instrument is corrected, the slope may be adjusted so that the instrument readout agrees with a standard ozone source or with the readout from another instrument whose calibration is considered to be accurate.

To change the calibration parameters, select **Cfg** from the **Main Menu**:

**Cfg Menu**  
**D/T Cal I/O Unt ←**

Now use the rotary select switch to select and click on **Cal**. The following submenu with the values of the current calibration parameters will then appear:

**Cal Menu**  
**Z=-2 S=1.01**

Here Z is the offset applied (in this case -2 ppbv) and S is the slope applied (in this case 1.01). The value of Z is added to the measured ozone value, and the

---

value of **S** is then multiplied by the measured ozone value. For example, if the instrument reads an average of 3 ppbv with the external scrubber in place, the value of **Z** should be set to  $-3$ . If after correction for the zero, the instrument consistently reads 2% low, the value of **S** should be set to 1.02.

When the **Cal Menu** first appears, the **Z** will be underlined with a cursor. You may rotate the Select switch to choose the calibration parameter **S** or **Z**. A single click on **S** or **Z** will select that parameter for change and activate a blinking cursor. Once **S** or **Z** is selected, its value can be changed by rotating the Select switch to the left or right. After choosing the desired value, a single click turns off the blinking cursor and allows you to scroll to the other parameter or to  $\leftarrow$  to exit the submenu. Once the values of **Z** and **S** are set, clicking on  $\leftarrow$  will return the display to the **Cfg** menu, and another click on  $\leftarrow$  will return to the **Main Menu**. The calibration parameters reside in non-volatile memory and are not affected by power failures.

### To Set the Time and Date

From the **Main Menu**, select the **Cfg** submenu. Next, select the **D/T** submenu. The display will read, for example:

**D/T: 14:32:21 ←**  
**17/10/2006**

meaning that it is 21 seconds after 2:32 p.m. on October 17, 2006 (military time and European date). To change a number in the date and time, rotate the Select switch to underline the numeral you want to change. A single click then causes a blinking cursor to cover that numeral. The number can then be changed by rotating the Select switch. Once the number is correct, click on the Select switch to turn off the blinking cursor. You may now rotate the Select switch to choose another numeral to change. Once the time and date is correct, clicking on  $\leftarrow$  will set the internal clock to that time and return the display to the **Cfg** menu. As in setting a digital watch, the seconds should be set in advance of the real time since the clock starts to run again only when the set time is entered; in this case by clicking on  $\leftarrow$ .

---

## To Change the Output Baud Rate

From the **Cfg** submenu, select **I/O** to give the input/output menu, for example:

**I/O Menu**  
**Bdr Ext LCD ←**

Selecting **Bdr** and clicking allows you to change the baud rate used for data transmission. The choices are 2400, 4800 and 19200 bps. The submenu appears as:

**2400 4800 19200 ←**

After clicking on a chosen baud rate, the display returns to the **I/O** menu.

## To Turn the Analog Inputs On and Off

Choosing **Ext** allows you to turn the analog inputs on and off and to set the scaling factor for analog outputs:

**Ext Menu**  
**Ext=On 1V=.200 ←**

Here, the external inputs are turned on, which means that measured voltages in the range 0-2.5 volts will be included in serial output and logged data. If there are no external inputs (e.g., external temperature, pressure and humidity sensors), then these measurements can be removed from the data stream by setting **Ext** to **Off**. This is done by selecting **On** or **Off** with the underline cursor, clicking to cause a blinking cursor, and rotating the Select switch to obtain the desired setting.

## To Change the Scale for the Analog Output

An analog output is provided via a BNC connector at the back of the instrument for those who want to record their data with a chart recorder or external logger. The full scale of the analog output is 2.5 V. The scaling of this output can be changed using the **I/O Menu**. The most sensitive output of 1V = 0.2 ppmv = 200 ppbv is normally used for measurements in the ambient atmosphere. This

---

corresponds to a range of 0-500 ppbv. The ozone measurement is linear to 100 ppmv, however, and a variable scaling of the output therefore is provided for measurements of high ozone levels. This scaling may be changed by accessing the **I/O Menu**. The scaling factor for the analog output is set by choosing the currently set value, e.g., **1V=.200**, clicking to obtain the blinking cursor, and rotating the Select switch to choose from the values **1V=0.200**, **1V=0.400**, **1V=4** and **1V=40**, corresponding to scalings of 1 volt equal to 0.2, 0.4, 4 and 40 ppmv (200, 400, 4000 and 40000 ppbv). The maximum analog output voltage is 2.5 volts, so the ranges covered are 0-500 ppb, 0-1 ppm, 0-10 ppm and 0-100 ppm for settings of **1V=.200**, **1V=0.400**, **1V=4** and **1V=40** settings, respectively. Once the correct scaling factor is chosen, click on the Select button to remove the blinking cursor. You may now scroll to ← and click to return to the **I/O** menu.

### **To Turn the Display Light On and OFF**

Selecting **LCD** from the **I/O Menu** allows you to turn the light of the front panel display on and off. To conserve power, use the Select switch to set the **LCD** submenu to **OFF**.

### **To Change the Units for Internal Temperature and Pressure**

From the **Cfg** menu, select **Unt** to give the following submenu, for example:

**Units Menu**  
**T:C P:mbar**

Rotating the Select switch will cycle the cursor between temperature (**T**) and pressure (**P**). Temperature units may be selected as either Kelvin (**K**) or Celsius (**C**) by first clicking to obtain the blinking cursor and then rotating the Select switch to obtain the desired units. Pressure units may be selected as either **torr** or **mbar**. A click on ← returns the display to the **Cfg** menu.

### **Lamp Test**

A diagnostic lamp test is provided in the **Lmp** submenu. When first entering the **Lmp** submenu, the voltage measured by the photodiode detector is

---

displayed. For best performance this voltage should be in the range 0.7-2.5 volts. For detector voltages less than about 0.7 volts, the data may be noisy due to insufficient light intensity to make precise measurements. If the voltage is zero, the lamp is not ignited and may have burned out. For voltages above 2.5 volts, the A/D converter is saturated and the measured ozone value will always be zero. This could happen if the instrument is very hot so that the lamp output is too bright.

Immediately following display of the detector voltage, the instrument starts measuring an “effective” ozone concentration without switching the solenoid valve on and off. This is an electronic zero and should after a few readings settle down to  $\pm$  a few ppbv. If the value is outside the range -9 to +9, the instrument may not be operating correctly. The display also gives a standard deviation of the electronic zero. For best results, the standard deviation should be not greater than  $\pm 2.5$ .

To exit the **Lmp** test mode, hold in the Select switch and release to return to the **Main Menu**.

The diagram on the following page summarizes the complete menu.

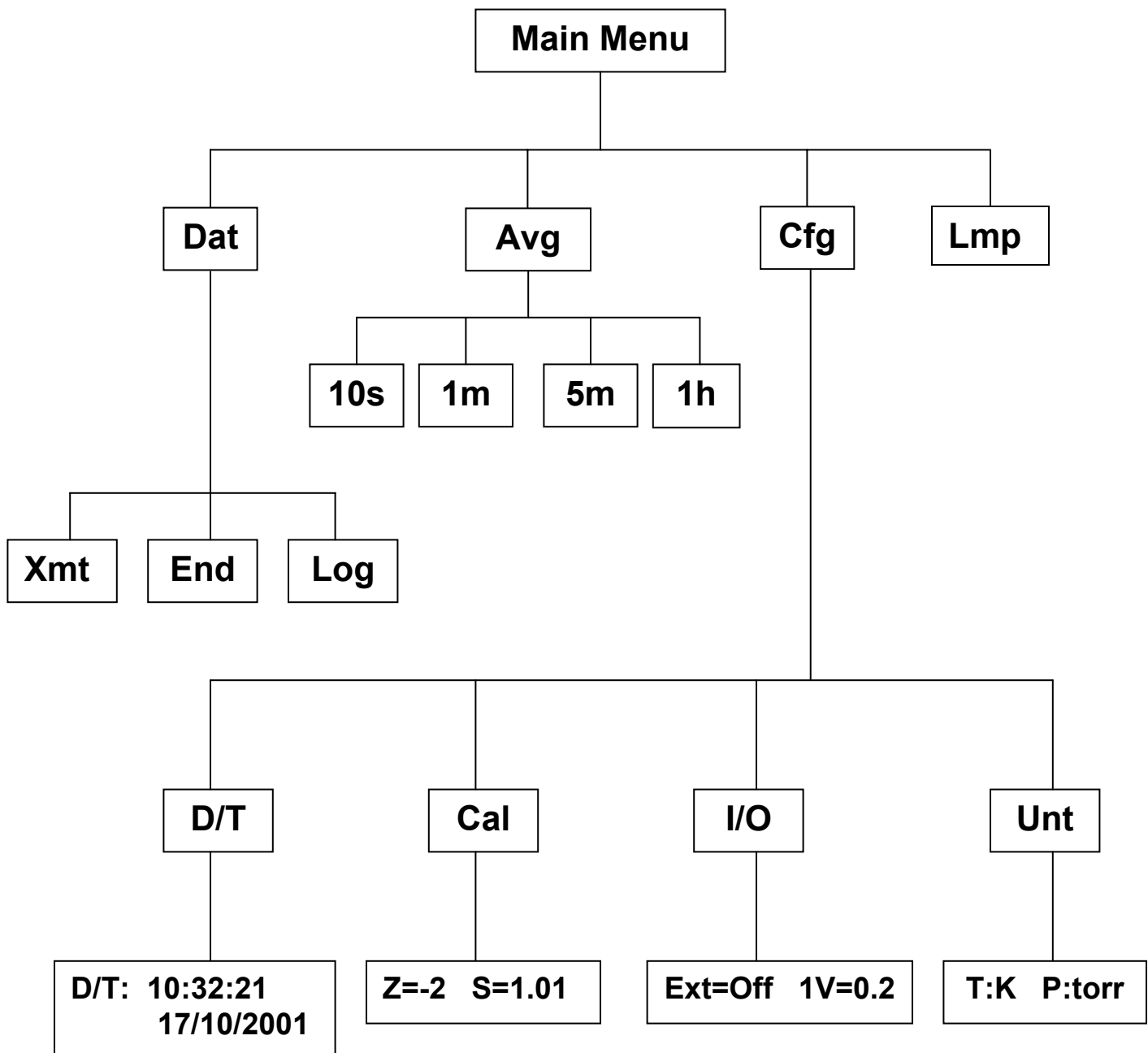

### 3. MAINTENANCE/TROUBLESHOOTING

The Ozone Monitor is designed to be nearly maintenance-free. The only component that requires routine maintenance is the ozone scrubber, which should be changed at least once every six months of operation. Other user serviceable components include the lamp, air pump, and solenoid valve, all of which are easily replaced should they fail. Also, the inlet filter (user supplied) should be changed as recommended by the filter manufacturer.

If the instrument fails to operate correctly, common problems can be identified and corrected using Table I. If the problem cannot be corrected, the instrument may be shipped to 2B Technologies for service. Please phone or email in advance for shipping instructions.

The figures following Table I provide a “guided tour” of the instrument so that critical components and connectors may be easily identified. A list of serviceable parts is provided in Section 4 at the end of this manual.

**Table I.** *Troubleshooting the Ozone Monitor for performance problems.*

Problem/symptom	Likely cause	Corrective action
<b><i>Instrument does not turn on.</i></b>	Power not connected properly or circuit breaker open.  Power cable not connected to circuit board.	Check external power connection for reverse polarity or a short and wait a few minutes for the thermal circuit breaker to reset.  Remove top cover and disconnect and reconnect power cable to circuit board.
<b><i>Instrument turns on then powers off.</i></b>	Burned out air pump.	Remove top cover and unplug air pump. Turn instrument on; if it remains running, then the air pump motor is burned out and shorting. Replace air pump.

<b><i>Display is blank or nonsense.</i></b>	Bad connection of display to circuit board.	Remove top cover and reconnect display to circuit board. Check solder connections to display.
<b><i>Cell temperature reads low by several 10's of degrees.</i></b>	Absent or loose connection of temperature probe cable to circuit board.	Remove top cover and reattach connector to circuit board.
<b><i>Readings are noisy with standard deviations greater than 2.0 ppbv.</i></b>	Lamp output is weak  Excessive vibration.  Flow path contaminated.	Remove top cover and check lamp connection to circuit board. Run Lamp Test from menu. If photodiode voltage is less than 0.7 V, replace lamp.  Provide additional vibration insulation for the instrument such as a foam pad.  Clean flow path with methanol according to the Cleaning Procedure.
<b><i>Analog output is constant or does not track front display.</i></b>	Cable not properly connected between analog output BNC and circuit board.  Wrong scaling factor selected In menu.	Remove top cover and reconnect cable between analog output and circuit board.  Check and reset analog output scaling factor in the Menu.
<b><i>Select switch does not work.</i></b>	Cable not properly connected between select switch and circuit board.	Remove top cover and reconnect select switch cable to circuit board.

<p><b>Serial port does not work.</b></p>	<p>Cable not properly connected between serial port 9-pin connector and circuit board.</p> <p>Wrong serial cable used.</p> <p>Wrong baud rate selected.</p>	<p>Remove top cover and reconnect serial port cable to circuit board.</p> <p>A “straight through” serial cable is provided. Some data collection devices require a “cross over” cable in which pins 1 and 3 are exchanged between the two ends of the cable. Use a “cross over cable or additional connector that switches pins 1 and 3.</p> <p>Make sure that the baud rate chosen in the menu matches the baud rate setting of your data acquisition program.</p>
<p><b>Required calibration parameters are outside the adjustable range (<math>\pm 9</math> ppbv offset and/or <math>\pm 9\%</math> slope) when calibrated using a standard ozone source or reliable ozone instrument.</b></p>	<p>Ozone scrubber is contaminated.</p> <p>Flow path is contaminated.</p> <p>Solenoid valve is contaminated and not opening and closing properly.</p> <p>Air pump is not drawing sufficient flow.</p>	<p>Replace ozone scrubber. Be sure to use an inlet filter to remove particulate matter.</p> <p>Clean flow path with methanol following the Cleaning Procedure.</p> <p>Remove solenoid valve, rinse with methanol, dry with zero air, and replace.</p> <p>As a first check, hold your finger over the air inlet to determine whether air is being drawn in. If there is flow, measure the flow rate by</p>

		removing the bottom cover and attaching a high conductance flow meter to the exit port of the pump. Air flow should be greater than 0.7 L/min. If flow is lower, check for leaks. If there are no leaks, replace air pump.
<b><i>Instrument always reads close to zero for ozone concentration.</i></b>	Solenoid valve cable is not properly connected to circuit board.	Reattach solenoid valve cable to circuit board.

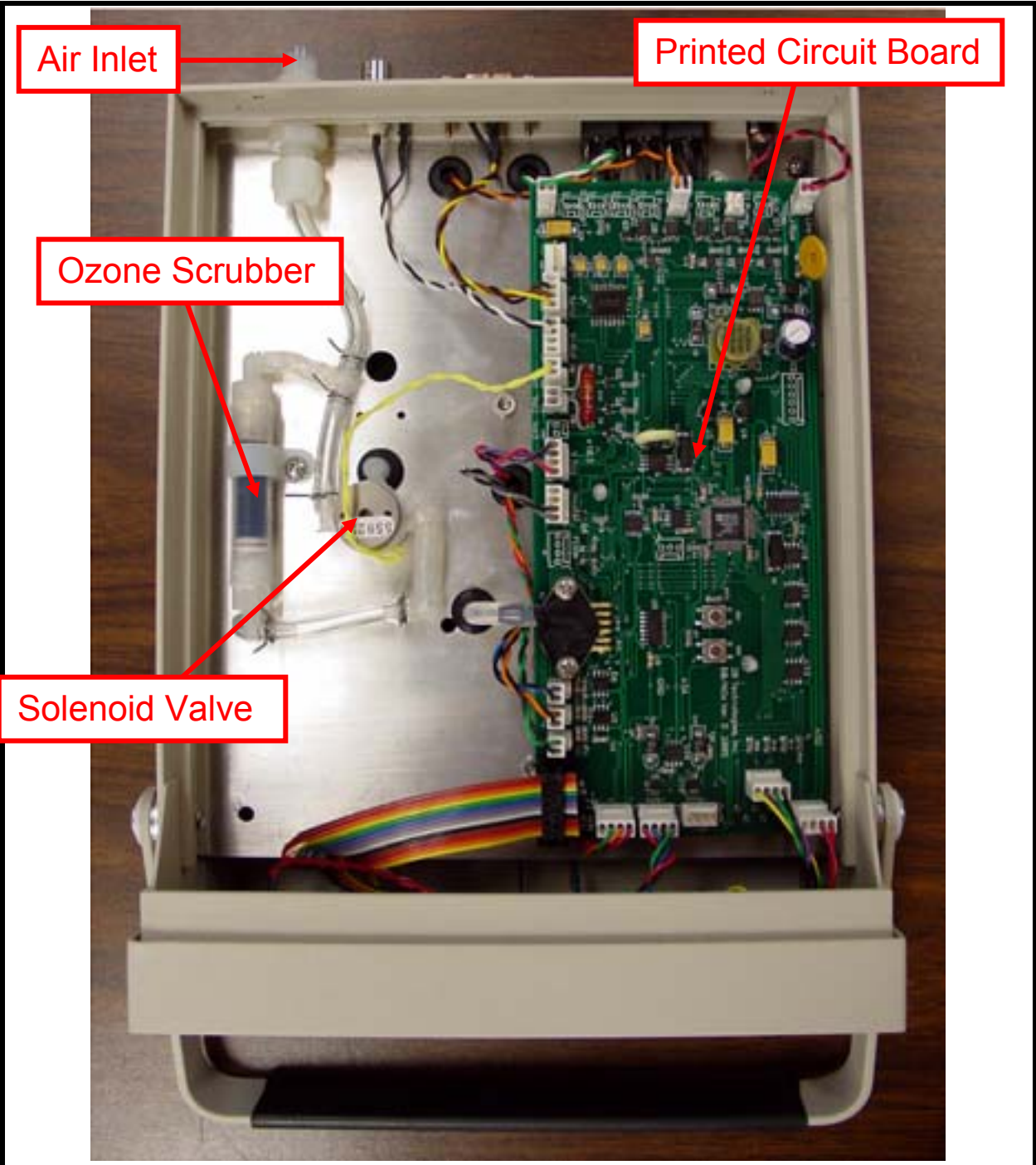

**FIGURE 3-1:** *Top view of Ozone Monitor with cover removed.*

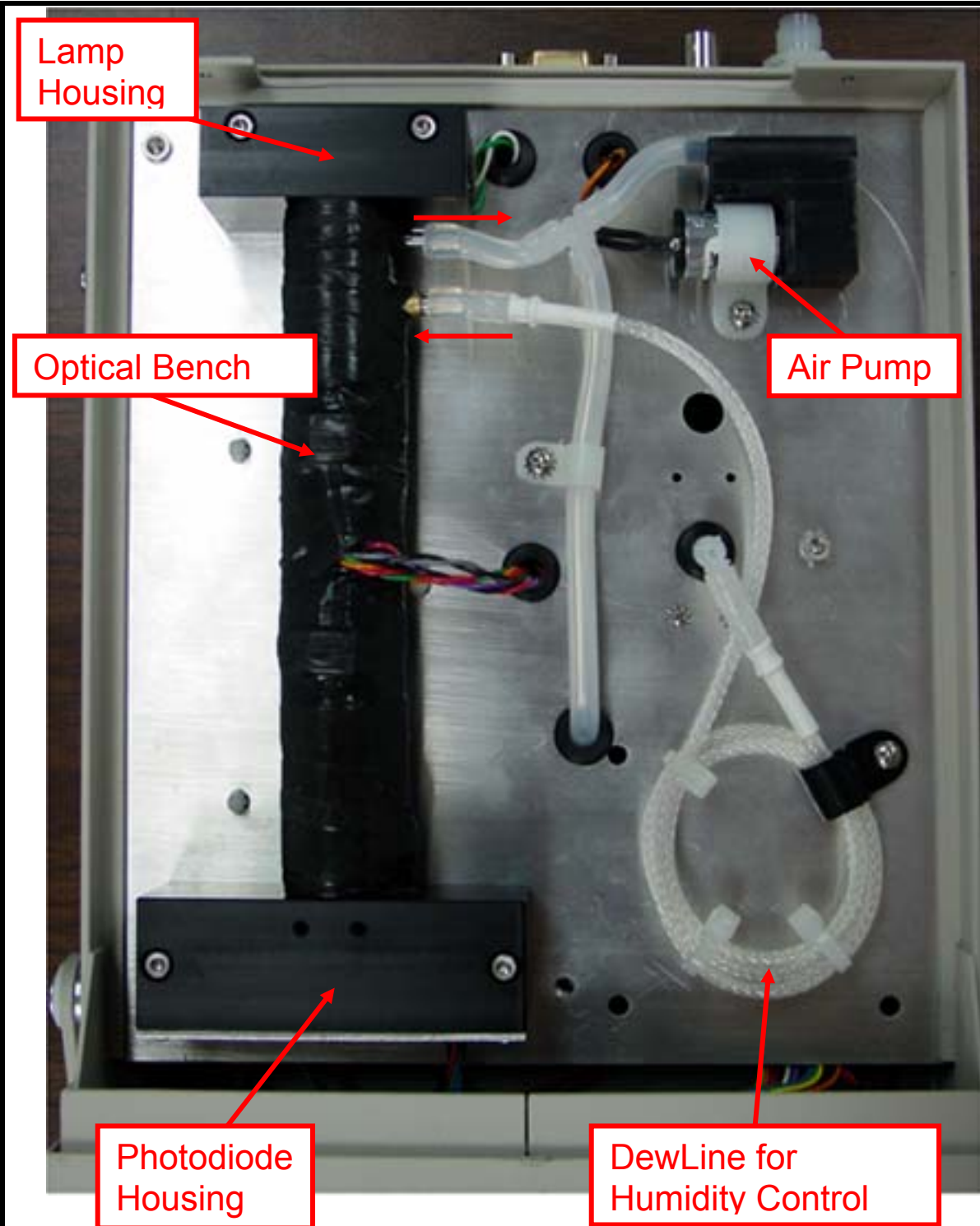

**FIGURE 3-2:** *Bottom view of Ozone Monitor with cover removed.*

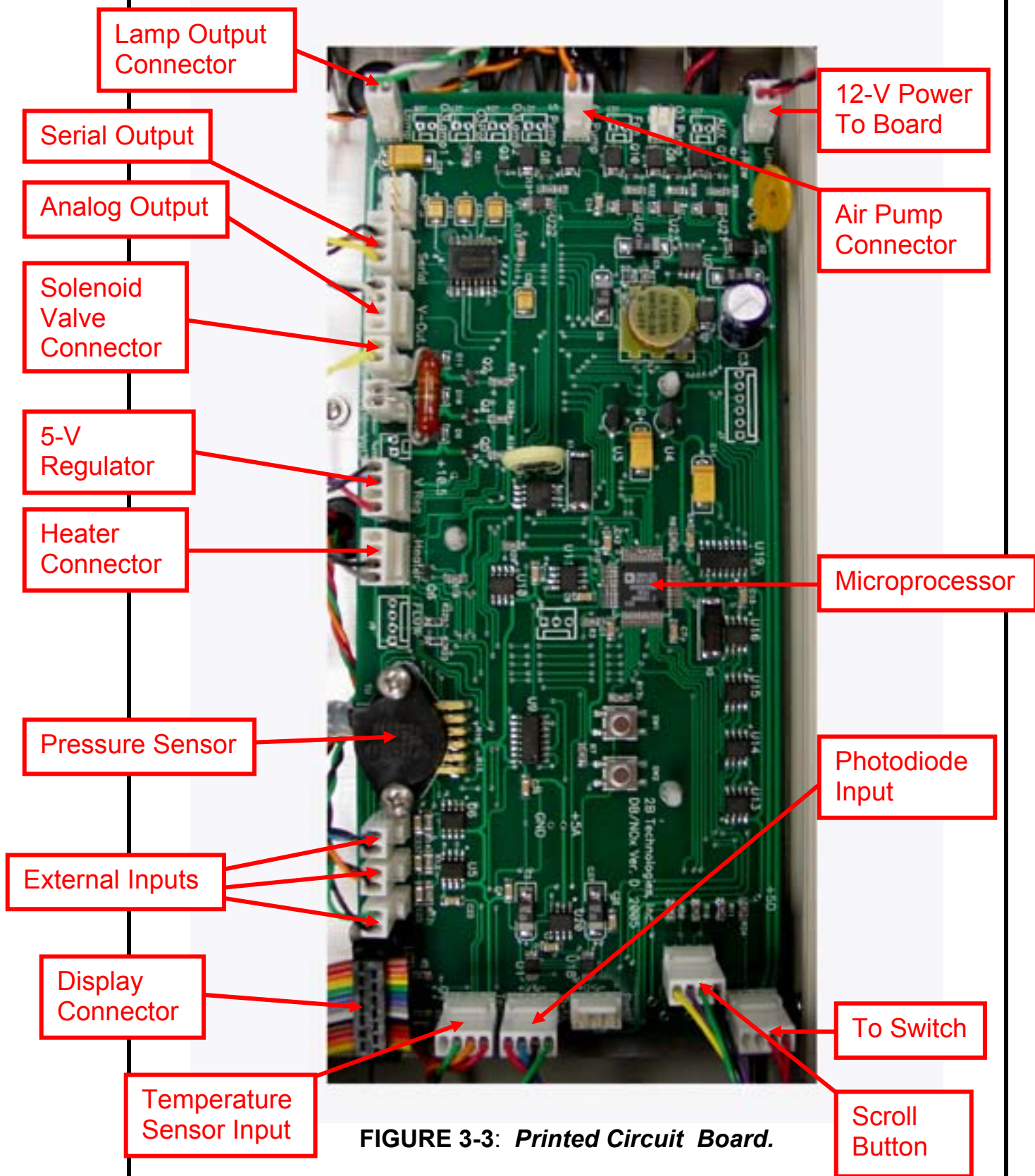

**FIGURE 3-3: Printed Circuit Board.**

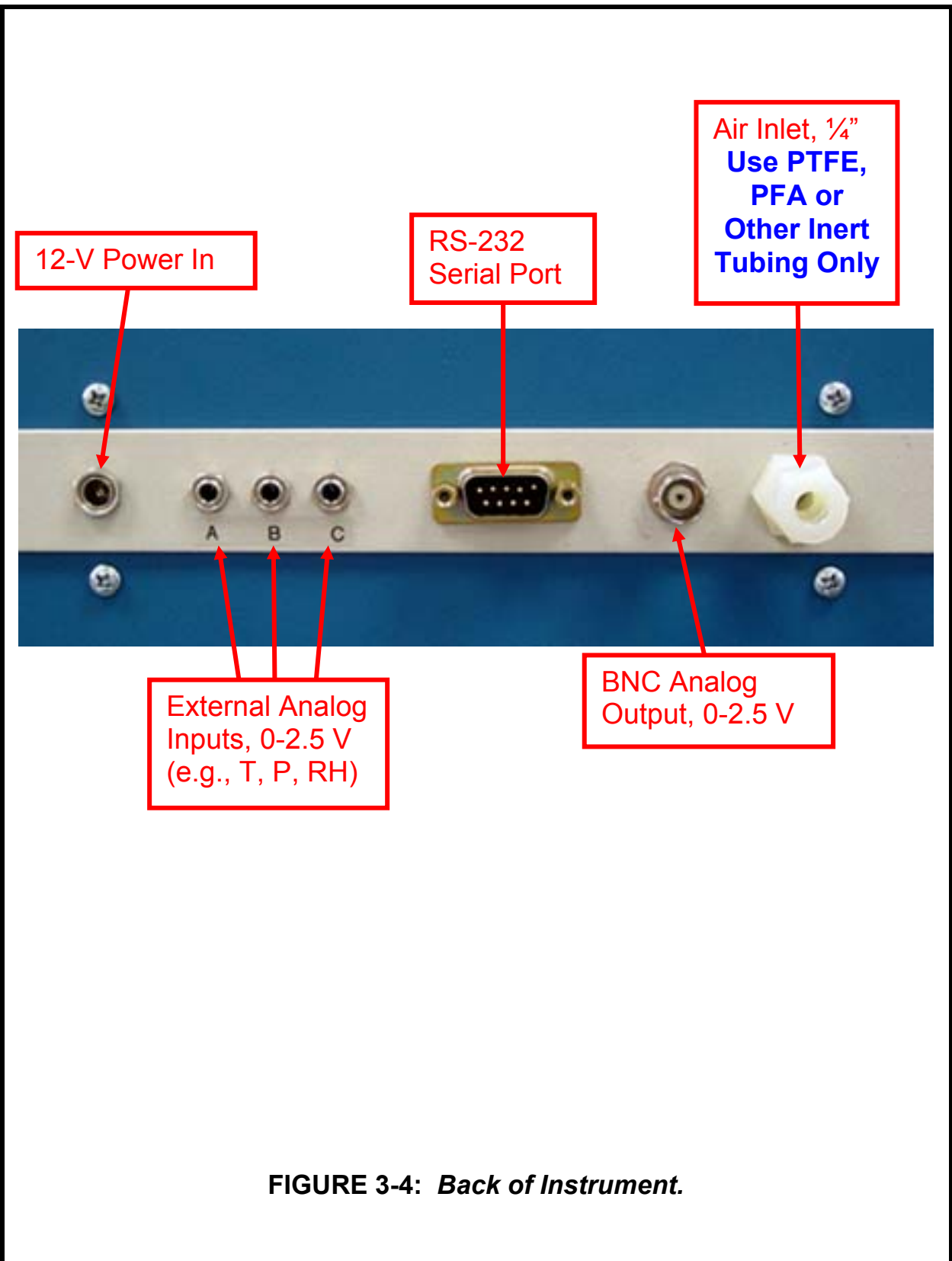

**FIGURE 3-4: *Back of Instrument.***

---

## 4. PARTS LIST

The following list includes those parts that are user serviceable.

<u>Part Number</u>	<u>Description</u>
SCRBINT	Ozone scrubber (internal)
SCRBEXT	Ozone scrubber (external)
OZLAMP	Lamp and cable
OZVLV	Solenoid valve
OZBRD	Circuit board without microprocessor
OZMCP	Microprocessor
OZDSP	LCD display and cable
OZPUMP	Air pump
PDASSY	Photodiode assembly and cable
OZCELL	Absorption cell
PWRASSY	Power connector/circuit breaker assembly
SERCABL	Serial port cable (to computer)
SERCON	Serial port connector and cable
BNCCON	Analog output BNC connector and cable
ANACON	Analog input connector
110ADP	110 V AC adapter
PWRWIR	Bare wire power cable
12VADP	12 V DC cigarette lighter adapter
TEFTYG	Teflon-lined Tygon® tubing
SILTUB	Silicone tubing