

# Ozone Calibration Source

**2B** *Technologies, Inc.*

## OPERATION MANUAL

**Model 306**

© Copyright 2011, 2B Technologies, Inc.  
All rights reserved.

# **TABLE OF CONTENTS**

<i>IDENTIFICATION RECORDS</i>	iii
<i>PRINTING HISTORY</i>	iv
<i>WARRANTY STATEMENT</i>	v
<i>WARNINGS</i>	vi
<i>OZONE CALIBRATION SOURCE INTRODUCTION</i>	1
<i>SPECIFICATIONS</i>	4
<i>OPERATION</i>	5
<i>THE LCD MENU</i>	6
<i>USING THE SERIAL INTERFACE</i>	11
<i>USING THE VOLTAGE OUTPUT</i>	12
<i>MAINTENANCE/TROUBLESHOOTING</i>	14
<i>PHOTOS</i>	17

## **IDENTIFICATION RECORDS**

Record the following information for future reference:

Unit serial number: \_\_\_\_\_

Warranty start date: \_\_\_\_\_  
(date of receipt)

## **PRINTING HISTORY**

New editions are complete revisions of the manual and incorporate all previous update pages and write-in instructions. This manual will be revised as necessary. Revisions can be in the form of new editions, update pages, or write-in instructions.

Revision A.....December 2006

Revision B.....April 2011

## **TRADEMARKS & PATENTS**

2B Technologies™, 2B Tech™, 2B™, Ozone Calibration Source™, and Ozone Cal Source™ are trademarks of 2B Technologies, Inc.

## **CONFIDENTIALITY**

The information contained in this manual may be confidential and proprietary, and is the property of 2B Technologies, Inc. Information disclosed herein shall not be used to manufacture, construct, or otherwise reproduce the goods disclosed herein. The information disclosed herein shall not be disclosed to others or made public in any manner without the expressed written consent of 2B Technologies, Inc.

© Copyright 2011, 2B Technologies, Inc.  
All rights reserved.

## **WARRANTY STATEMENT**

2B Technologies, Inc. warrants its products against defects in materials and workmanship. 2B Technologies will, at its option, repair or replace products which prove to be defective. The warranty set forth is exclusive and no other warranty, whether written or oral, is expressed or implied. 2B Technologies specifically disclaims the implied warranties of merchantability and fitness for a particular purpose.

### **Warranty Periods**

The warranty period is one (1) year from date of receipt by the purchaser, but in no event more than thirteen (13) months from original invoice date from 2B Technologies, Inc.

### **Warranty Service**

Warranty Service is provided to customers through phone support, Monday - Friday, from 9:00 a.m. to 5:00 p.m., Mountain Time USA. Phone support is for troubleshooting and determination of parts to be shipped from 2B Technologies to the customer in order to return the product to operation within stated specifications. If phone support is not efficient and effective, the product may be returned to 2B Technologies for repair or replacement. Prior to returning the product, a Repair Authorization Number (RA) must be obtained from the 2B Technologies Service Department.

### **Shipping**

2B Technologies will pay freight charges for replacement or repaired products shipped to the customer site. Customers shall pay freight charges for all products returning to 2B Technologies.

### **Conditions**

The foregoing warranty shall not apply to defects resulting from improper or inadequate maintenance, adjustment, calibration or operation by customer. Maintenance, adjustment, calibration or operation must be performed in accordance with instructions stated in the Ozone Calibration Source™ manual. Usage of maintenance materials purchased from suppliers other than 2B Technologies will void this warranty.

### **Limitation of Remedies and Liability**

The remedies provided herein are the Customer's sole and exclusive remedies. In no event shall 2B Technologies be liable for direct, indirect, special, incidental or consequential damages (including loss of profits) whether based on contract, tort or any other legal theory. The Ozone Calibration Source™ manual is believed to be

accurate at the time of publication and no responsibility is taken for any errors that may be present. In no event shall 2B Technologies be liable for incidental or consequential damages in connection with or arising from the use of the Ozone Calibration Source™ manual and its accompanying related materials. Warranty is valid only for the country designated on the 2B Technologies quote or invoice.

## **Safety Warning**

The Model 306 Ozone Calibration Source is designed specifically to produce ozone. Ozone is a toxic gas and should be handled with caution. The same kind of care should be taken in handling the output of the Ozone Cal Source as for any other toxic gas that, for example, may come from a compressed gas cylinder. Under normal operating conditions, the instrument will produce ozone in air at concentrations up to 1 to 2 ppm. The main danger is from inhalation of such high concentrations of ozone. As a safety measure, a cap is provided for the ozone outlet. When the cap is properly secured all of the ozonated air is diverted through an ozone scrubber inside the instrument. When attached to an ozone monitor, the ozone may be exhausted to the ambient environment by the ozone monitor, depending on the ozone monitor design. Thus, when calibrating ozone monitors, one should know in advance how the ozone exhaust is handled. It may be necessary to attach an ozone scrubber either prior to or after the ozone monitor air pump. Alternatively, one can perform the calibration inside a chemical hood. 2B Technologies provides inexpensive, high conductance ozone scrubbers that can be used to scrub the exhaust of ozone monitors.

## ENGLISH



### **WARNING:**

Any operation requiring access to the inside of the equipment, could result in injury. To avoid potentially dangerous shock, disconnect from power supply before opening the equipment.

### **WARNING:**

This symbol, , on the instrument indicates that the user should refer to the manual for operating instructions.

### **WARNING:**

If this instrument is used in a manner not specified by 2B Technologies, Inc. USA, the protection provided by the instrument may be impaired.

## ESPAÑOL



### **ATENCIÓN:**

Cualquier operación que requiera acceso al interior del equipo, puede causar una lesión. Para evitar peligros potenciales, desconectarlo de la alimentación a red antes de abrir el equipo.

### **ATENCIÓN:**

Este símbolo, , en el instrumento indica que el usuario debería referirse al manual para instrucciones de funcionamiento.

### **ATENCIÓN:**

Si este instrumento se usa de una forma no especificada por 2B Technologies, Inc., USA, puede desactivarse la protección suministrada por el instrumento.

## FRANÇAIS



### **ATTENTION:**

Chaque opération à l'intérieur de l'appareil, peut causer du préjudice. Afin d'éviter un shock qui pourrait être dangereux, déconnectez l'appareil du réseau avant de l'ouvrir.

### **ATTENTION:**

Le symbol, , indique que l'utilisateur doit consulter le manuel d'instructions.

### **ATTENTION:**

Si l'instrument n'est pas utilisé suivant les instructions de 2B Technologies, Inc., USA, les dispositions de sécurité de l'appareil ne sont plus valables.

## DEUTSCH



### **WARNHINWEIS:**

Vor dem Öffnen des Gerätes Netzstecker ziehen!

### **WARNHINWEIS:**

Dieses, , auf dem Gerät weist darauf hin, daß der Anwender zuerst das entsprechende Kapitel in der Bedienungsanleitung lesen sollte.

### **WARNHINWEIS:**

Wenn das Gerät nicht wie durch die Firma 2B Technologies, Inc., USA, vorgeschrieben und im Handbuch beschrieben betrieben wird, können die im Gerät eingebauten Schutzvorrichtungen beeinträchtigt werden.

## ITALIANO



### **ATTENZIONE:**

Qualsiasi intervento debba essere effettuato sullo strumento può essere potenzialmente pericoloso a causa della corrente elettrica. Il cavo di alimentazione deve essere staccato dallo strumento prima della sua apertura.

### **ATTENZIONE:**

Il simbolo, , sullo strumento avverte l'utilizzatore di consultare il Manuale di Istruzioni alla sezione specifica.

### **ATTENZIONE:**

Se questo strumento viene utilizzato in maniera non conforme alle specifiche di 2B Technologies, Inc. USA, le protezioni di cui esso è dotato potrebbero essere alterate.

## DUTCH



### **OPGELET:**

Iedere handling binnenin het toestel kan beschadiging veroorzaken. Om iedere mogelijk gevaarlijke shock te vermijden moet de aansluiting met het net verbroken worden, vóór het openen van het toestel.

### **OPGELET:**

Het symbool, , geeft aan dat de gebruiker de instructies in de handleiding moet raadplegen.

### **OPGELET:**

Indien het toestel niet gebruikt wordt volgens de richtlijnen van 2B Technologies, Inc., USA gelden de veiligheidsvoorzieningen niet meer.

## **1. OZONE CALIBRATION SOURCE INTRODUCTION**

The Model 306 Ozone Calibration Source™ (OCS™) is a portable source of ozone that allows one to calibrate any ozone monitor. The instrument scrubs ozone from ambient air and produces either zero air or air having a mixing ratio of ozone in the range 30-1,000 parts-per-billion by volume (ppbv). The desired ozone concentration is chosen from the easy-to-use menu using a rotary select switch. The instrument can be programmed to output up to 10 individual ozone step concentrations over a chosen time interval. The total output volumetric flow rate is 3.0 L/min, and the ozone mixing ratio is controlled so as to be independent of ambient temperature, pressure and humidity.

You can attach the Ozone Cal Source™ output directly to the inlet of any ozone monitor (providing that its sampling rate is less than 3.0 L/min); the excess flow is vented through an ozone scrubber internal to the OCS™. Besides portability, an important advantage of the Model 306 OCS™ is that it provides a known concentration of ozone in ambient air containing the same level of humidity as the air sample to be measured.

The Ozone Cal Source™ is factory calibrated against a NIST-traceable ozone standard. However, the calibration parameters may be changed in the menu in case the user wants to recalibrate the OCS™ against a separately maintained standard; i.e., the Ozone Cal Source™ can be used as a transfer standard. The OCS™ may be used, for example, for maintaining the calibration of a large number of ozone monitors in the field relative to a highly stable laboratory instrument. In this case, a huge advantage of the OCS™ is its portability.

Besides its use as a calibrator of ozone monitors, the Ozone Cal Source™ may be used as a calibrated ozone source for studies of the effects of ozone on materials (rubber, plastics, paints, etc.) and on biological organisms such as plants.

### **Theory of Operation**

The portable Ozone Calibration Source makes use of a low pressure mercury lamp to photolyze oxygen and produce ozone. The vacuum UV lines near 185 nm are absorbed by O<sub>2</sub> to produce oxygen atoms. The oxygen atoms attach to O<sub>2</sub> to form ozone, O<sub>3</sub>. The well known mechanism, which is responsible for the presence of Earth's protective ozone layer, is as follows

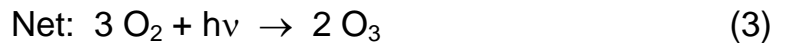
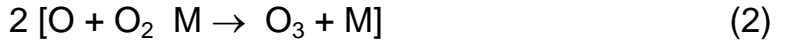

where  $h\nu$  symbolizes a photon of light and M is any molecule (e.g.,  $\text{N}_2$ ,  $\text{O}_2$ , Ar). Absorption of one photon of light by  $\text{O}_2$  results in the formation of two ozone molecules. The concentration of ozone produced in a flowing stream of air depends on the intensity of the photolysis lamp, the concentration of oxygen (determined by pressure and temperature), and the residence time in the photolysis cell (determined by volumetric flow rate and cell volume). By holding these parameters constant, it is possible to produce a flow of air containing a constant concentration of ozone, and the concentration of ozone produced can be varied most conveniently by varying the lamp intensity. Figure 1 is a schematic diagram of the Ozone Calibration Source.<sup>TM</sup>

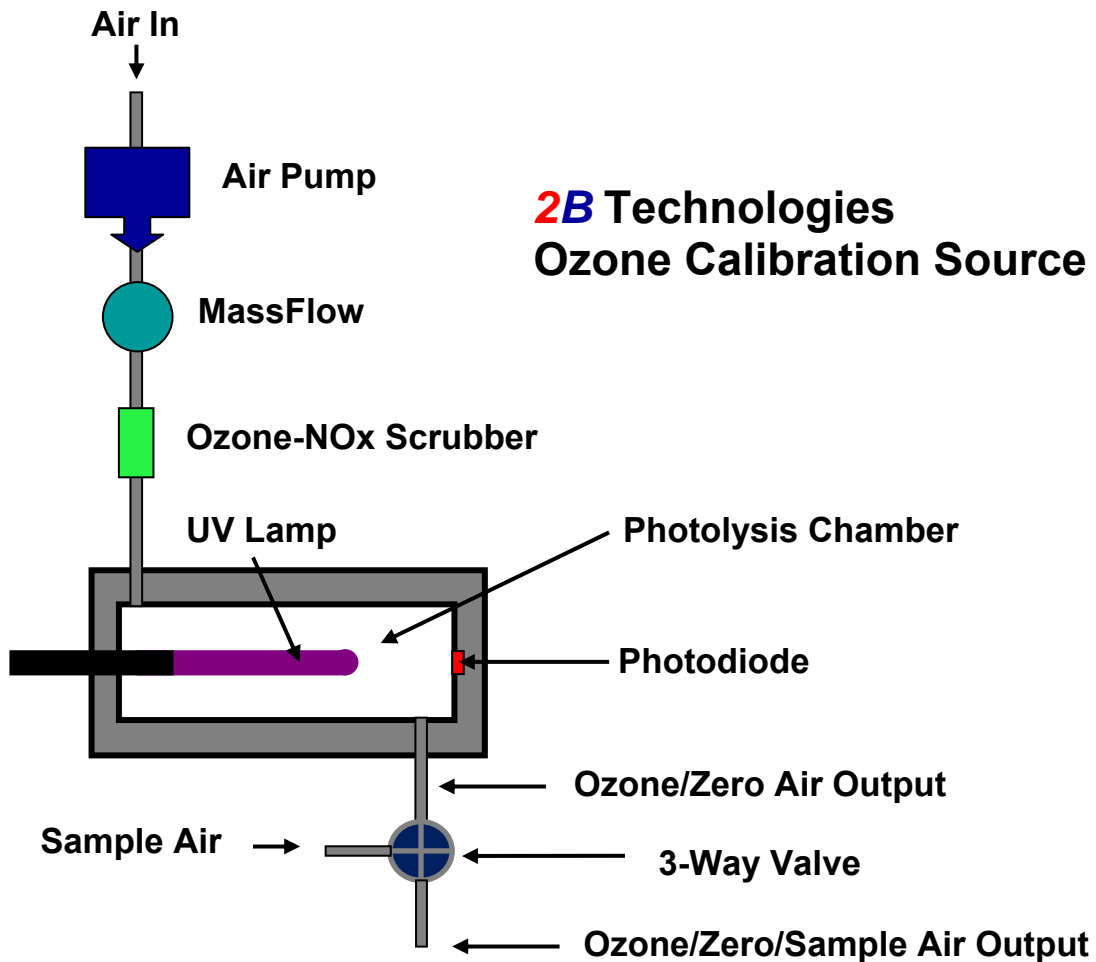

Figure 1. Schematic diagram of the Model 306 Ozone Calibration Source<sup>TM</sup>.

## Summary of Schematic

An air pump pushes air through a particle filter, then through a mass flow meter. The microprocessor controls the flow rate at a value of 3.0 L/min volumetric by means of pulse-width modulation of the power to the pump. Before entering the photolysis chamber, the air passes through an ozone/NO<sub>x</sub> scrubber to remove any ambient ozone and NO<sub>x</sub>. The air then passes through the photolysis chamber containing a low-pressure mercury lamp where absorption of atomic lines near 185 nm produces ozone. The lamp intensity is monitored by a photodiode and controlled by the microprocessor. The photodiode voltage is calibrated against the output ozone concentration. Pressure within the gas stream is measured but not controlled. Instead, the lamp intensity is varied to compensate in changes in pressure using a proprietary algorithm. Air containing ozone exits the photolysis cell, through an overflow tee where excess air not sampled by the ozone monitor being calibrated is exhausted through an internal ozone scrubber via an overflow tee. If it is desired to have the full 3.0 L/min of air/ozone exit the instrument, the internal ozone scrubber may be capped. The other end of the overflow tee goes to a valve which selects either the ambient sample air or the calibration air to exit through the output of the 306.

## OZONE CALIBRATION SOURCE™ SPECIFICATIONS

<i>Power Requirements</i> .....	11-14 V DC or 110/220 V AC , 18 watt
<i>Dimensions</i> .....	3.5” x 8.3” x 11.6”
<i>Weight</i> .....	5.6 lbs (2.6 kg)
<i>Ozone Output</i> .....	0 ppb and 30-1,000 ppb
<i>Output Flow Rate</i> .....	3.0 L/min volumetric
<i>Precision</i> .....	higher of 2.0 ppbv or 1.5%
<i>Accuracy</i> .....	higher of 2.0 ppbv or 1.5%
<i>Rise Time (95%)</i> .....	< 30s to reach 95% of selected concentration
<i>Outputs</i> .....	RS232, LCD Display, Voltage(0-2.5V)

## **2. OPERATION**

Please read all the following information before attempting to install the Ozone Calibration Source™. For assistance, please call 2B Technologies at (303)273-0559 or email us at [techsupport@twobtech.com](mailto:techsupport@twobtech.com).

### **NOTE:**

**Save the shipping carton and packing materials that came with the Ozone Calibration Source™. If the Ozone Calibration Source™ must be returned to the factory, pack it in the original carton. Any repairs as a result of damage incurred during shipping will be charged.**

### **Shipping Box Contents**

Open the shipping box and verify that it contains the following:

1. Ozone Calibration Source™
2. 110-220 V AC power adapter
3. Cigarette lighter adapter
4. Bare-wire 12 V DC battery adapter
5. Serial port cable
6. Tubing Connector to Ozone Monitor
7. ¼" Ozone Outlet Cap
8. Operating Manual
9. Birth Certificate
10. Calibration Data Sheet

If anything is missing or obviously damaged, contact 2B Technologies immediately.

### **Operation of the Ozone Calibration Source™**

To operate the Ozone Calibration Source™, connect it to an external power source and turn the instrument on by flipping the front panel switch. The instrument requires a 12 V DC source which can be supplied by: 1) the 110-220 V AC power adapter (2.5 amp or higher), 2) a cigarette lighter adapter

plugged into a 12 V DC source such as found in an automobile or many light aircraft, or 3) a 12 V battery. The source can be in the range 11-14 V DC without any detrimental effects on the measurement. When using a battery, be certain to attach the positive (red) and negative (black) wires correctly. A circuit breaker and diode are installed on the circuit board in case of an electrical short or incorrect battery attachment. If activated, the breaker will reset itself after a few minutes.

Once turned on, the instrument will briefly display the version number of the software installed on the microprocessor. The instrument will then display

**Warming up ...**  
**delT = -xx.x**

where **delT** is the deviation of the temperature of the photolysis chamber from the set point of 315 K (42 °C). As the chamber warms up, the temperature deviation will be continuously displayed. During the warmup period, the photolysis lamp and the pump are turned off and the internal 3-way valve is off to divert sample air to the output of the Model 306. This allows for the Model 306 to be connected in series with a monitor to perform remote calibrations. Even though the instrument is capable of producing greater than 1,000 ppbv of ozone, the upper limit to the concentration that can be accurately controlled should be assumed to be 1,000 ppbv.

Once **delT** is within 1 °C of the set point, the display will read:

**Temperature Set**  
**Press Select**

## **The LCD Menu**

Anytime after powering the instrument on, you may enter the main menu by holding in the rotary select switch until the menu appears. Once the menu appears, release the select switch. (Note: You may enter the menu without waiting for the warm up to be complete; however the ozone concentration selected will not be accurately output until the set point temperature is reached.)

The following diagram summarizes the complete LCD menu.

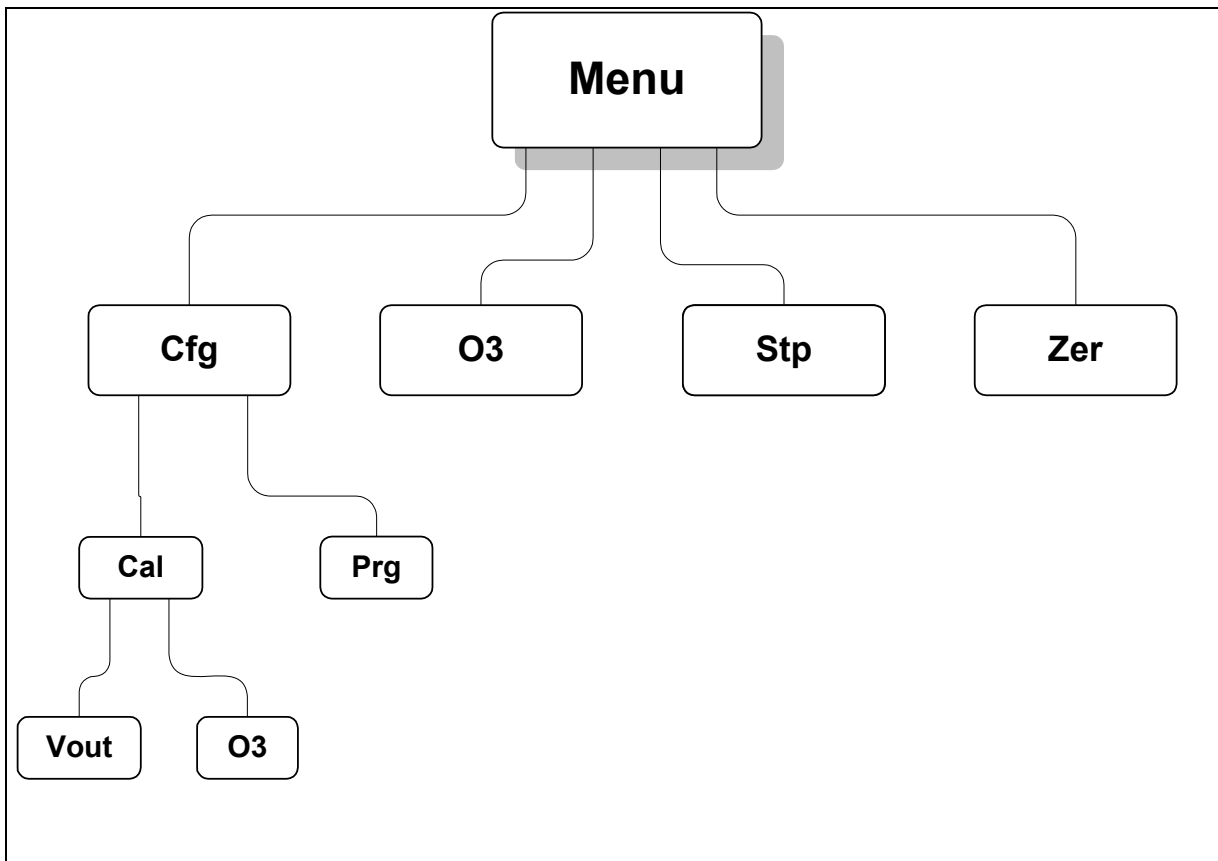

After pressing the select button the main menu will then be displayed as:

**Menu**  
**Cfg O3 Stp Zer**

Rotating the select switch will move the blinking cursor to highlight the first character of each of the four submenus, **Cfg**, **O3**, **Stp** and **Zer**. One can enter any one of these submenus by rotating the select switch to move the cursor over the first letter of the submenu and then momentarily pressing (“clicking”) the select switch.

### **Configuration Menu (Cfg)**

Selecting the **Cfg** submenu will produce the following display:

**Cfg Menu**  
**Cal Prg ←**

where **Cal** is a submenu for entering the calibration menu and **Prg** is a submenu for defining a programmed series of step ozone concentrations. The purpose of the return symbol (←) is to return to the previous menu; i.e., depressing the select switch when ← is highlighted allows one to move one level up in the menu. The function of each submenu is described below.

Choosing the **Cal** submenu results in the following submenu:

**Cal Menu**  
**Vout O3 ←**

where **Vout** is a submenu for setting the voltage offset value and **O3** is a submenu for setting the calibration factors for Ozone output. Choosing **Vout** results in the following submenu:

**Vout Offset Menu**  
**Offset= 10 mV ←**

There is an inherent electronic offset in the analog output used to output the ozone level being produced and to provide error messages. The voltage offset, **Vout**, is adjustable from 0 to 99 millivolts, and this setting is used to adjust the voltage output downward to 0.05 V for zero ozone output. More details are provided on page 12.

Choosing O3 results in the following submenu for setting the zero offset and slope for ozone output.:

**O3 Cal Menu**  
**Z= 2 S= 1.05 ←**

The Ozone Cal Source™ is shipped with a NIST-traceable calibration. The calibration factors, **Z** and **S**, are set in the instrument and recorded in the instrument's calibration document and birth certificate. However, you may choose to change the calibration factors so that the instrument output agrees with your own ozone standard. You can always return the instrument to its factory calibration if desired. To change the calibration factor, place the cursor over the **Z** or **S** and hold in the select switch until the cursor blinks. You may now change the value of the calibration factors by rotating the select switch. Increasing the slope (**S**) calibration factor increases the ozone output concentration linearly; i.e., for S=1.10, the ozone concentration produced will

be 10% higher than for S=1.00, and for S=0.95 it will be 5% lower. Once the desired value of **S** is selected, momentarily press the select switch such that the cursor no longer blinks. You may now exit the **Cal** submenu by selecting and clicking on ←.

Choosing the **Prg** submenu from the **Cfg** menu, allows one to define a program of steps in ozone concentration. Choosing **Prg** results in the following submenu:

**Prg Menu**  
**Num Steps= x** ←

Upon placing the cursor under the currently set value x and clicking, a blinking cursor will appear. You may now rotate the select switch to obtain the number of steps, up to 10, you wish to have in your program. Clicking again will turn off the blinking cursor and you may return the cursor to ← to begin defining the program. After choosing the number of steps, the following submenu will appear:

**Prg Menu**  
**Time/Step= x** ←

You may now move the cursor to the currently set time/step value x, click to obtain a blinking cursor and rotate the select switch to choose a step time in the range 1 to 60 minutes. To select the value, click to remove the blinking cursor, then use ← to begin defining the target concentrations of each of the steps. The following submenu will now appear:

**Select O3 Step**  
**Step[1]= xxxx** ←

Where xxxx is the target ozone concentration in ppbv that is currently being used for the first step of the program. You may now change the ozone concentration for the first concentration step in the same way that the Time/step was changed. Executing ← will bring up the following submenu and allow you to set the target concentration for the next step:

**Select O3 Step**  
**Step[2]= xxxx** ←

This process is repeated until the target concentrations are set for all of the steps in your program.

This program resides in memory until the next time you choose to change it.

## Ozone Menu (O3)

You may choose to output a constant ozone concentration by choosing **O3** from the main menu. Upon clicking on **O3**, the following submenu will appear:

### Select Amount

O3= xxxx ←

You may change the desired target ozone concentration by selecting xxxx and rotating the select switch to choose a value. To start producing that concentration of ozone, click on ←. The instrument will now output the selected concentration of ozone until you enter menu again and change the target concentration. As an example, the display will read as follows

Target= 200 ppb  
delT=-0.1 ■■■■■■

if you have chosen 200 ppb as the target concentration. The deviation of the photolysis chamber temperature from the target temperature is displayed in addition to a series of six solid or open bars. When all bars are solid the lamp intensity is within range to produce the target concentration.

The selected target ozone concentration will remain in memory until the next time you change it. Bear in mind that the instrument will output up to 1,000 ppbv of ozone reliably. Higher concentrations may be chosen, but the instrument may not be capable of delivering the concentration chosen. For higher target concentrations, you will need to independently measure the maximum concentration of ozone that the instrument can output and regulate.

## Start Step Menu (Stp)

Choosing **Stp** executes the program of concentration steps you have stored in memory (under **Cfg/Prg**). The target concentrations are displayed as the instruments steps through the program. For example, the first display might read

Step[1]=100 ppb  
delT=0.2 ■■■■■■

if you have chosen 100 ppb as the target concentration for your first step and the photolysis chamber is higher than the target value by 0.2 °C. The six solid bars indicate that the cell temperature and lamp intensity are within range for accurate output of the selected ozone concentration.

## Zero Menu (Zer)

This submenu provides a rapid way to produce air containing 0 ppb of ozone. In this mode, the photolysis lamp is turned off.

## Using the Serial Interface

The serial menu and serial commands can be used to control the functionality of the Model 306. Use the serial port by connecting a straight-through serial cable between the Model 306 serial output connector and a computer with a serial port or a USB port with a Serial to USB adapter. Anytime after powering the instrument on, you may enter the serial menu by sending a character using a terminal emulator such as Tera Term Pro (downloadable from the following hyperlink: <http://hp.vector.co.jp/authors/VA002416/teraterm.html>) or Hyperterminal (provided on almost all Windows-based computers). The terminal emulator's connection settings can be found on page 12 of this manual.

The following is a list of commands and descriptions available through the serial interface:

<b>run step</b>	Starts the stored step program
<b>output ozone</b>	Continuous output of ozone selected (prompts user to enter desired ozone concentration)
<b>set slope</b>	Prompts user to enter new slope in format x.xx
<b>set zero</b>	Prompts user to enter new zero
<b>set steps</b>	Prompts user to enter step program (# of steps, time/step, concentration for each step)
<b>hibernate</b>	Pump off, lamp off, maintains temperature control with heater on (waits for wakeup through serial port or select switch)
<b>hibernate -nt</b>	Pump off, lamp off, heater off (waits for wakeup through serial port or select switch)
<b>v</b>	Opens the calibration valve to allow ozone into stream.
<b>c</b>	Closes the calibration valve to allow sample air into stream.
<b>?</b>	Displays this menu
<b>x</b>	Exits the serial menu
<b>n</b>	Skips to next concentration while running step and exits continuous output of ozone
<b>l</b>	Turns LCD backlight ON

- o Turns LCD backlight OFF
- header** Describes the values in the serial data output

## Hibernate Feature

Most remote applications require low power consumption. The Model 306 has the ability to enter a “hibernation” mode where the firmware powers only the essentials to consume less power while waiting to perform a calibration.

- **hibernate** Entering this command turns the pump and lamp off while maintaining the set temperature of the photolysis chamber and awaits a character through the serial port or select switch press to wake out of hibernation. \*\*Useful for cold weather applications for on-demand calibrations.
- **hibernate –nt** Entering this command turns the pump, lamp, and heater off and awaits a character through the serial port or select switch press to wake out of hibernation. \*\*Useful where power is very limited.

## Using the Voltage Output

If equipped with a BNC connector, a voltage signal can be monitored from the Model 306 which is proportionally scaled to the ozone output setting. When set to output zero, the voltage output will be 0.05 Volts. If this zero setting is greater than 0.05 V, adjustment can be made from the Vout menu to subtract the voltage offset above 0.05 V. The voltage output ranges from 0.05 V to 1.05 V for ozone output. The scaling factor is 1mV/ppb. For example, if set to output 200 ppb of ozone, the voltage output should be 0.25 Volts (0.05 + 0.001\*Ozone). All error voltages are 1.55 V to 2.00 V, as described below. An output signal below 0.05 V indicates that the 3-way valve is powered off and the output air is from the sample inlet.

## Errors and Corresponding Voltage outputs

TEMPERATURE LOW ERROR 1.55 V  
TEMPERATURE HIGH ERROR 1.60 V  
FLOW LOW ERROR 1.65 V  
FLOW HIGH ERROR 1.70 V  
INTENSITY LOW ERROR 1.75 V  
INTENSITY HIGH ERROR 1.80 V  
FLOW and TEMPERATURE ERROR 1.85 V  
FLOW and INTENSITY ERROR 1.90 V  
TEMPERATURE and INTENSITY ERROR 1.95 V  
FLOW, TEMPERATURE, and INTENSITY ERROR 2.00 V

## Attaching the Ozone Cal Source™ to an Ozone Monitor

For calibration of an ozone monitor, outlet tubing may be attached to the ¼-inch stainless steel Swagelok fitting on the back of the instrument. The inlet tubing should be made of PTFE (Teflon®), PFA or some other inert material that does not destroy ozone and that does not desorb plasticizers and other organics that can contaminate the flow path. The length of tubing should be kept as short as possible (not more than a few feet) to minimize ozone destruction. Tygon®, polypropylene (which may look like Teflon) and metal tubing should not be used. Teflon-lined Tygon tubing, which is supplied with the instrument provides the flexibility of Tygon and the inertness of Teflon.

The Ozone Cal Source™ may be attached directly to the ozone monitor; excess ozone flow will be diverted through an ozone scrubber internal to the OCS™, and any perturbation in total flow rate will be automatically adjusted by the microprocessor using feedback from the mass flow meter.

## Collecting Diagnostic Data over the Serial Port in Real Time

To transmit diagnostic data to a computer over the serial port in real time, connect the Ozone Calibration Source™ to the serial port of the computer using the 9-pin cable provided. If your computer does not have a serial port, you can use a serial-to-USB adapter, available at most computer stores. Activate your data acquisition software; e.g., Hyperterminal (available on most Windows®-based computers) or Tera Term Pro (provided on the cd supplied with the instrument and downloadable from the 2B Tech website: [www.twobtech.com](http://www.twobtech.com)). The latter software is preferred since Hyperterminal has a 500-line buffer limit, but the user may set the maximum buffer size for Tera Term Pro to 10,000 lines. Both programs allow you to log data to a computer file with no limit on number of data lines. Using these terminal emulation programs, data may be saved to a text file and then opened in Microsoft Excel (or other spread sheet program) where it may be converted to formatted data in columns by defining delimiters (such as commas and carriage returns) for data manipulation and graphing.

For data transfer the correct settings are:

Baud rate: 4800

Data bits: 8

Parity: None

Stop bits: 1

Flow control: None or hardware

Serial data lines are output approximately once every second as follows:

Lamp Intensity (arbitrary units), Temperature (K), Pressure (Torr), Volumetric Flow Rate (L/min), Lamp Duty Cycle (%), Valve Duty Cycle (%), Heater Duty Cycle (%)

Collecting serial data for a few minutes can be extremely useful in diagnosing a problem with the Ozone Cal Source. If you have a problem, please collect a data file and email it to [techsupport@twobtech.com](mailto:techsupport@twobtech.com) along with a description of the problem.

### **3. MAINTENANCE/TROUBLESHOOTING**

The Ozone Calibration Source™ is designed to be nearly maintenance-free. The only component that requires routine maintenance is the ozone scrubber, which should be changed at least once every six months of operation. Other user serviceable components include the lamp, air pump and solenoid valve, all of which are easily replaced should they fail.

If the instrument fails to operate correctly, common problems can be identified and corrected using Table I. If the problem cannot be corrected, the instrument may be shipped to 2B Technologies for service. Please phone or email in advance for shipping instructions.

The figures following Table I provide a “guided tour” of the instrument so that critical components and connectors may be easily identified. A list of serviceable parts is provided in Section 4 at the end of this manual.

**Table I.** Troubleshooting the Ozone Cal Source™ for performance problems.

Problem/symptom	Likely cause	Corrective action
<b><i>Instrument does not turn on.</i></b>	Power not connected properly or circuit breaker open.	Check external power connection for reverse polarity or a short and wait a few minutes for the thermal circuit breaker to reset.
	Power cable not connected to circuit board.	Remove top cover and disconnect and reconnect power cable to circuit board.
<b><i>Instrument turns on then powers off.</i></b>	Burned out air pump.	Remove top cover and unplug air pump. Turn instrument on; if it remains running, then the air pump motor is burned out and shorting. Replace air pump.
<b><i>Display is blank or nonsense.</i></b>	Bad connection of display to circuit board.	Remove top cover and reconnect display to circuit board. Check solder connections to display.
<b><i>Target temperature is never reached.</i></b>	Absent or loose connection of temperature probe cable to circuit board.	Remove top cover and reattach connector to circuit board.
	Heater is burned out	Replace cartridge heater.
<b><i>Instrument does not output ozone.</i></b>	Photolysis lamp is burned out.	Replace lamp and recalibrate instrument.
	Cable not properly connected between lamp	Remove top cover and reconnect lamp cable to

	and circuit board.	circuit board.
<b>Select switch does not work.</b>	Cable not properly connected between select switch and circuit board.	Remove top cover and reconnect select switch cable to circuit board.
<b>Serial port does not work.</b>	<p>Cable not properly connected between serial port 9-pin connector and circuit board.</p> <p>Wrong serial cable used.</p> <p>Wrong baud rate selected.</p> <p>Wrong com port assigned.</p>	<p>Remove top cover and reconnect serial port cable to circuit board.</p> <p>A “straight through” serial cable is provided. Some data collection devices require a “cross over” cable in which pins 1 and 3 are exchanged between the two ends of the cable. Use a “cross over cable or additional connector that switches pins 1 and 3.</p> <p>Make sure that the baud rate is set to 4800</p> <p>Make sure that the com port assigned by your computer matches the com port setting in your terminal emulator (Tera Term Pro or Hyperterminal).</p>

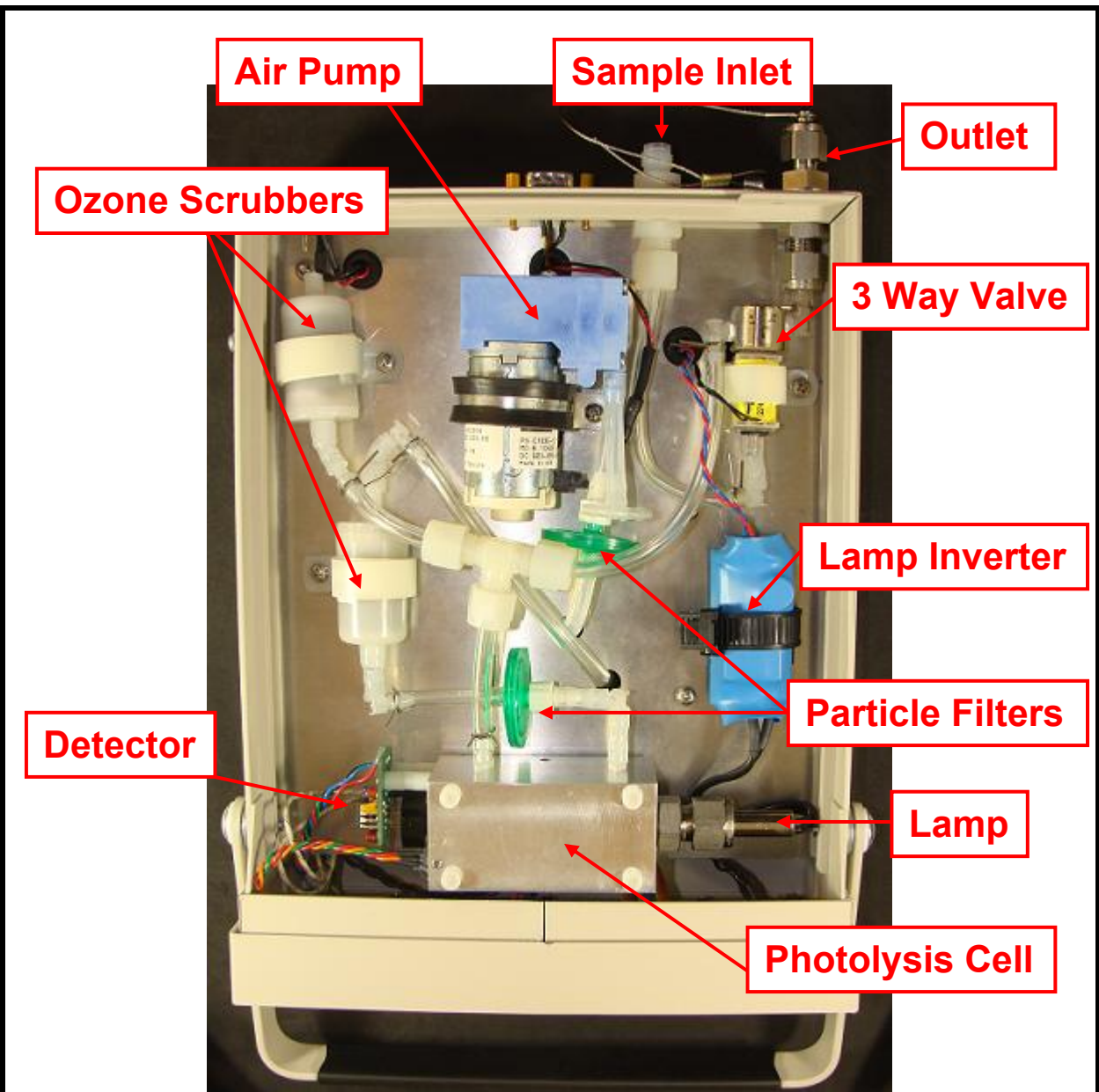

**FIGURE 3-1: Bottom view of Ozone Cal Source™ with cover removed.**

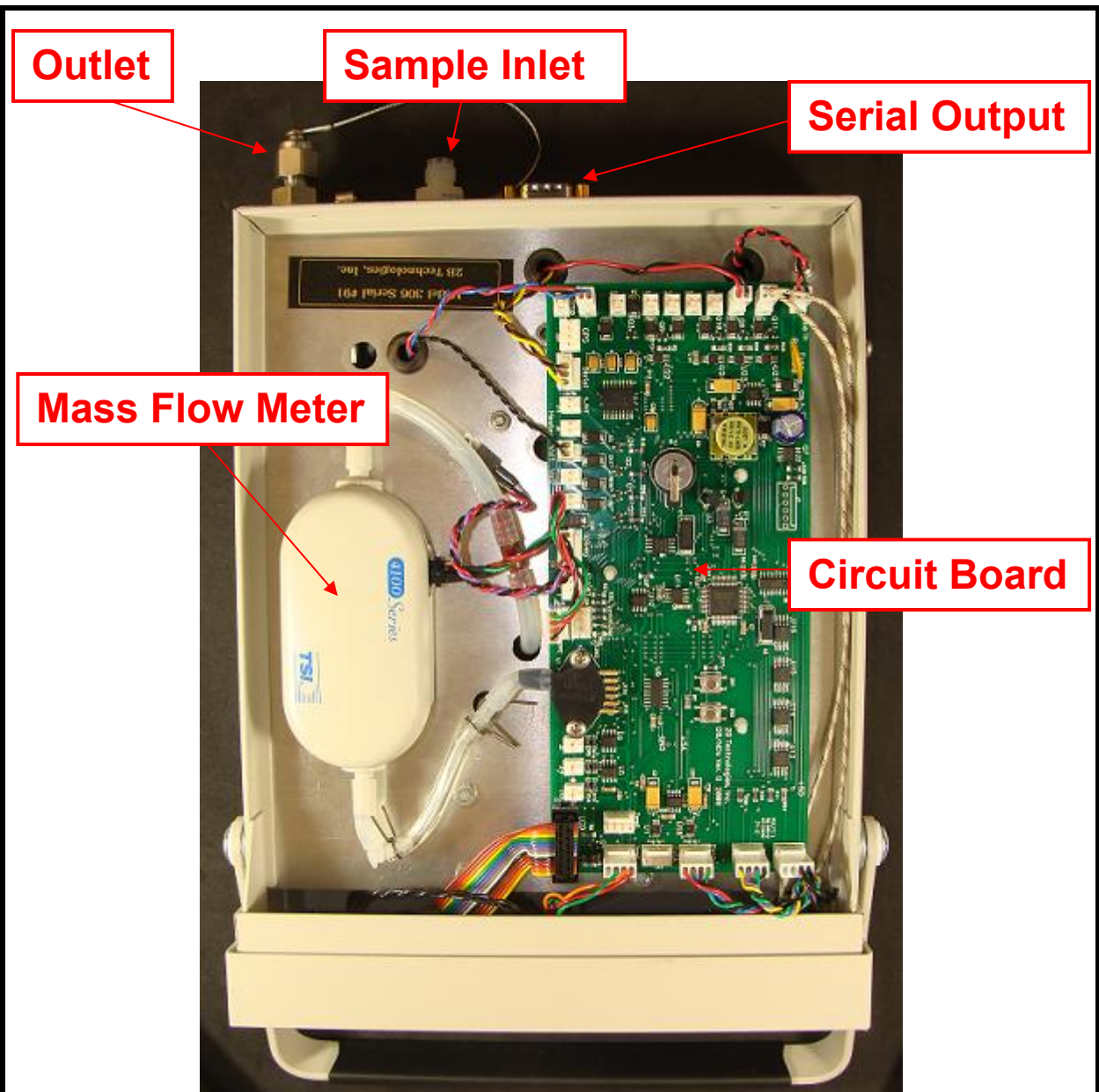

**FIGURE 3-2: Top view of Ozone Cal Source™ with cover removed**

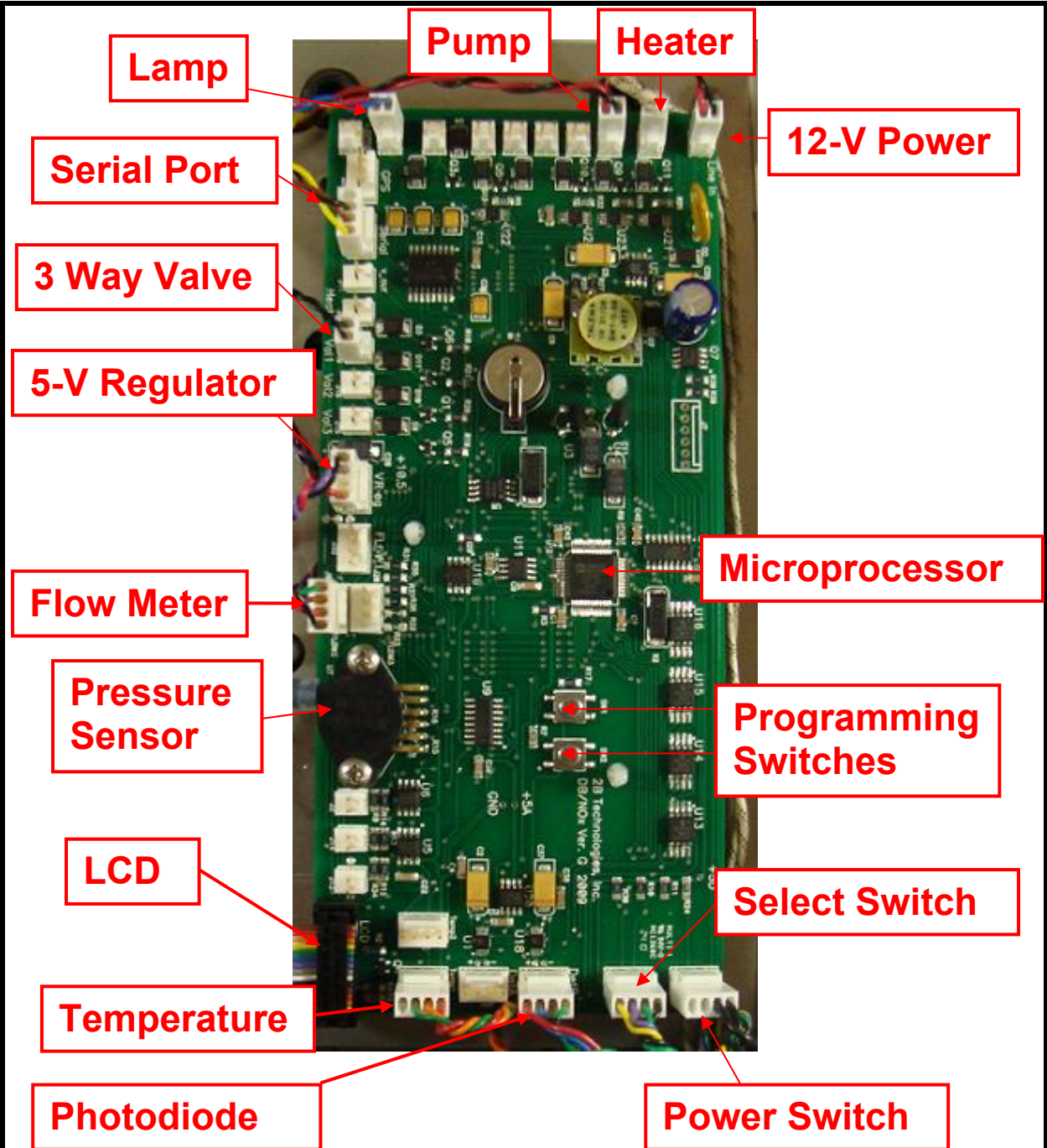

**FIGURE 3-3: Printed Circuit Board.**