

Nitric Oxide Monitor

2B *Technologies, Inc.*

OPERATION MANUAL

Model 410

© Copyright 2010, 2B Technologies, Inc.
All rights reserved.

TABLE OF CONTENTS

<i>IDENTIFICATION RECORDS</i>	iii
<i>PRINTING HISTORY</i>	iv
<i>WARRANTY STATEMENT</i>	v
<i>WARNINGS</i>	vii
<i>NITRIC OXIDE MONITOR INTRODUCTION</i>	1
<i>SPECIFICATIONS</i>	7
<i>OPERATION</i>	8
<i>PRE-OPERATION FLOW SETTING</i>	8
<i>MAINTENANCE/TROUBLESHOOTING</i>	24
<i>PARTS LIST</i>	33

IDENTIFICATION RECORDS

Record the following information for future reference:

Unit serial number: _____

Warranty start date: _____
(date of receipt)

PRINTING HISTORY

New editions are complete revisions of the manual and incorporate all previous update pages and write-in instructions. This manual will be revised as necessary. Revisions can be in the form of new editions, update pages, or write-in instructions.

Revision A.....March 2010

Revision B..... August 2010

Revision COctober 2010

TRADEMARKS & PATENTS

2B Technologies™, 2B Tech™, 2B™, NO Monitor™, Nitric Oxide Monitor™ and NOzone™ are trademarks of 2B Technologies, Inc.

CONFIDENTIALITY

The information contained in this manual may be confidential and proprietary, and is the property of 2B Technologies, Inc. Information disclosed herein shall not be used to manufacture, construct, or otherwise reproduce the goods disclosed herein. The information disclosed herein shall not be disclosed to others or made public in any manner without the expressed written consent of 2B Technologies, Inc.

© Copyright 2010, 2B Technologies, Inc.
All rights reserved.

WARRANTY STATEMENT

2B Technologies, Inc. warrants its products against defects in materials and workmanship. 2B Technologies will, at its option, repair or replace products which prove to be defective. The warranty set forth is exclusive and no other warranty, whether written or oral, is expressed or implied. 2B Technologies specifically disclaims the implied warranties of merchantability and fitness for a particular purpose.

Warranty Periods

The warranty period is one (1) year from date of receipt by the purchaser, but in no event more than thirteen (13) months from original invoice date from 2B Technologies, Inc.

Warranty Service

Warranty Service is provided to customers through phone support, Monday - Friday, from 9:00 a.m. to 5:00 p.m., Mountain Time USA, or by submission of a tech support ticket at www.twobtech.com/techsupport. Phone support is for troubleshooting and determination of parts to be shipped from 2B Technologies to the customer in order to return the product to operation within stated specifications. If phone support is not efficient and effective, the product may be returned to 2B Technologies for repair or replacement. Prior to returning the product, a Repair Authorization Number (RA) must be obtained from the 2B Technologies Service Department.

Shipping

2B Technologies will pay freight charges for replacement or repaired products shipped to the customer site. Customers shall pay freight charges for all products returning to 2B Technologies.

Conditions

The foregoing warranty shall not apply to defects resulting from improper or inadequate maintenance, adjustment, calibration or operation by customer. Maintenance, adjustment, calibration or operation must be performed in accordance with instructions stated in the Nitric Oxide Monitor Operation Manual. Usage of maintenance materials purchased from suppliers other than 2B Technologies will void this warranty.

Limitation of Remedies and Liability

The remedies provided herein are the Customer's sole and exclusive remedies. In no event shall 2B Technologies be liable for direct, indirect, special, incidental or consequential damages (including loss of profits) whether based on contract, tort or any other legal theory. The Nitric Oxide Monitor Operation Manual is believed to be

accurate at the time of publication and no responsibility is taken for any errors that may be present. In no event shall 2B Technologies be liable for incidental or consequential damages in connection with or arising from the use of the Nitric Oxide Monitor Operation Manual and its accompanying related materials. Warranty is valid only for the country designated on the 2B Technologies quote or invoice.

ENGLISH



WARNING:

Any operation requiring access to the inside of the equipment, could result in injury. To avoid potentially dangerous shock, disconnect from power supply before opening the equipment.

WARNING:

This symbol,  on the instrument indicates that the user should refer to the manual for operating instructions.

WARNING:

If this instrument is used in a manner not specified by 2B Technologies, Inc. USA, the protection provided by the instrument may be impaired.

ESPAÑOL



ATENCION:

Cualquier operación que requiera acceso al interior del equipo, puede causar una lesión. Para evitar peligros potenciales, desconectarlo de la alimentación a red antes de abrir el equipo.

ATENCION:

Este símbolo,  en el instrumento indica que el usuario debería referirse al manual para instrucciones de funcionamiento.

ATENCION:

Si este instrumento se usa de una forma no especificada por 2B Technologies, Inc., USA, puede desactivarse la protección suministrada por el instrumento.

FRANÇAIS



ATTENTION:

Chaque opération à l'intérieur de l'appareil, peut causer du préjudice. Afin d'éviter un shock qui pourrait être dangereux, déconnectez l'appareil du réseau avant de l'ouvrir.

ATTENTION:

Le symbol,  indique que l'utilisateur doit consulter le manuel d'instructions.

ATTENTION:

Si l'instrument n'est pas utilisé suivant les instructions de 2B Technologies, Inc., USA, les dispositions de sécurité de l'appareil ne sont plus valables.

DEUTSCH



WARNHINWEIS:

Vor dem Öffnen des Gerätes Netzstecker ziehen!

WARNHINWEIS:

Dieses,  auf dem Gerät weist darauf hin, daß der Anwender zuerst das entsprechende Kapitel in der Bedienungsanleitung lesen sollte.

WARNHINWEIS:

Wenn das Gerät nicht wie durch die Firma 2B Technologies, Inc., USA, vorgeschrieben und im Handbuch beschrieben betrieben wird, können die im Gerät eingebauten Schutzvorrichtungen beeinträchtigt werden.

ITALIANO



ATTENZIONE:

Qualsiasi intervento debba essere effettuato sullo strumento può essere potenzialmente pericoloso a causa della corrente elettrica. Il cavo di alimentazione deve essere staccato dallo strumento prima della sua apertura.

ATTENZIONE:

Il simbolo,  sullo strumento avverte l'utilizzatore di consultare il Manuale di Istruzioni alla sezione specifica.

ATTENZIONE:

Se questo strumento viene utilizzato in maniera non conforme alle specifiche di 2B Technologies, Inc. USA, le protezioni di cui esso è dotato potrebbero essere alterate.

DUTCH



OPGELET:

Iedere handeling binnenin het toestel kan beschadiging veroorzaken. Om iedere mogelijk gevaarlijke shock te vermijden moet de aansluiting met het net verbroken worden, vóór het openen van het toestel.

OPGELET:

Het symbool,  geeft aan dat de gebruiker de instructies in de handleiding moet raadplegen.

OPGELET:

Indien het toestel niet gebruikt wordt volgens de richtlijnen van 2B Technologies, Inc., USA gelden de veiligheidsvoorzieningen niet meer.

1. NITRIC OXIDE MONITOR INTRODUCTION

The 2B Technologies Nitric Oxide Monitor is designed to enable accurate measurements of nitric oxide (NO) concentrations in air without the use of a calibration gas standard. The most common application is the measurement of NO in urban and regional air pollution where the concentration is a few ppb or higher. Because of the absolute nature of the measurement, the Nitric Oxide Monitor may also be used to quantify the concentrations of calibration gas standards required by other techniques such as the commonly used NO + O₃ chemiluminescence method. The highly sensitive chemiluminescence method is required when the NO concentration is ≤ 2 ppb. For measurements at low ppb levels and higher the Nitric Oxide Monitor has advantages over chemiluminescence of portability (small size and weight, low power consumption) and lack of requirement of a gas calibration standard. A U.S. patent (U.S. Patent No. 7,045,359; May 16, 2006) has been issued for this new detection technique. The Model 410 NO Monitor may be used in combination with the Model 401 NO₂ Converter for measurement of NO_x, and NO₂ may be determined by difference (NO₂ = NO_x – NO), as in the chemiluminescence method.

Theory of Operation

The NOzone™ technology employed by the Model 410 Nitric Oxide Monitor™ is based on the quantitative reaction of nitric oxide (NO) with ozone (O₃):



This reaction has long been used as a gas phase titration for the measurement of either NO or O₃ in laboratory kinetics experiments, and the reaction is stoichiometric; i.e., one O₃ molecule is consumed for every NO molecule oxidized to NO₂ in the reaction. In the Model 410 Nitric Oxide Monitor™, a small concentration of ozone (~4 ppm) is added to the gas sample stream and the resulting decrease in concentration of ozone is measured by the absolute method of UV absorbance. By providing adequate time for the reaction to go to completion, the decrease in ozone concentration is equal to the original concentration of NO in the gas stream.

Reaction (1) also is used in conventional chemiluminescence analyzers. Instead of measuring the change in ozone concentration, chemiluminescence detects the small amount of light produced in the reaction. That light is emitted

by electronically excited NO_2 molecules formed in reaction (1). Chemiluminescence instruments are highly sensitive and have a very fast response time, but require frequent calibration using a gas standard.

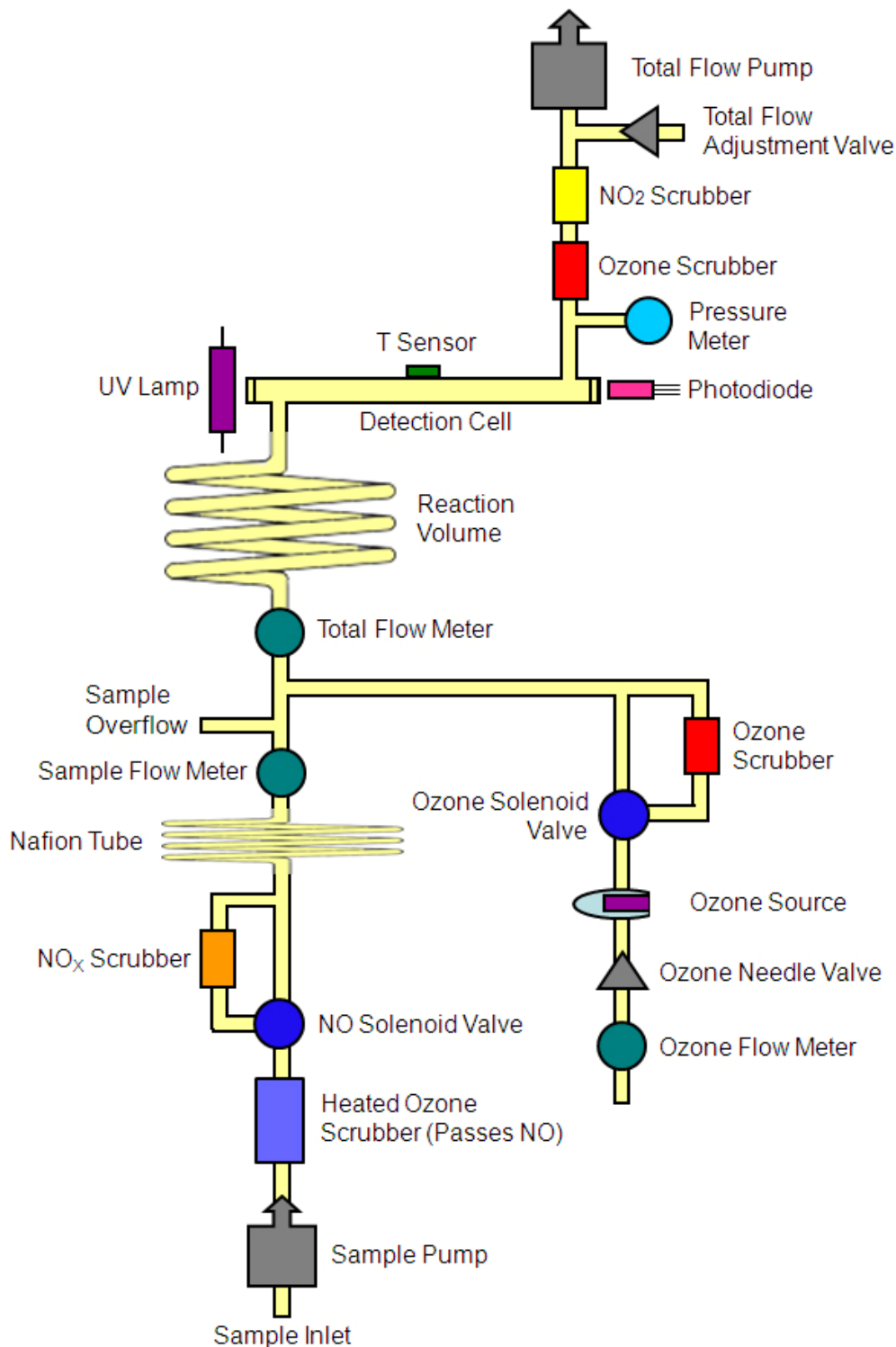

Fig. 1. Schematic diagram of the Model 410 Nitric Oxide Monitor

Figure 1 is a schematic diagram of the Model 410 Nitric Oxide Monitor. Here we trace the gas flow through the instrument beginning at the Sample Inlet near the bottom of the diagram.

A miniature air pump, the Sample Pump, pushes sample air into the instrument and through a proprietary heated ozone scrubber at a flow rate of ~0.8-1.2 L/min. The air sample then passes through a miniature solenoid valve which alternately directs the flow through a NO_x scrubber or bypass. The flow then passes through a Nafion tube, the Sample Flow Meter and into an overflow tee which vents part of the air sample. The Nafion tube equilibrates the humidity of the sampled air with that inside the instrument case, assuring that the humidity is the same in NO_x-scrubbed and unscrubbed air. The Total Flow Pump (top of diagram) draws air from the overflow tee and through the Total Flow Meter to measure the Total Flow through the reaction coil and detection cell. A bleed valve, the Total Flow Adjustment Valve, is used to provide course adjustment of the Total Flow rate through the detection cell. Pulse-width modulation of the motor of the Total Flow Pump is used to adjust the Total Flow rate to be in the range 550-650 cc/min. Following the sampling tee, a small flow of 20-30 cc/min of ozonized air also is drawn into the sample air stream by the Total Flow Pump. The flow rate of ozone/air is adjusted by use of the Ozone Needle Valve.

The sample air, either NO-scrubbed or unscrubbed, containing the added ozone, next passes through a coiled reactor, which provides adequate reaction time (typically 3.5-4.5 s) for nearly all NO in the sample to react with ozone via reaction (1) above. A small correction is made in the software for lack of complete reaction. That correction, which depends on the flow rate, ozone concentration and temperature, is typically less than 3%. Next the sample air passes through the Detection Cell where UV light intensity is measured. The air stream then passes through an Ozone Scrubber where O₃ is catalytically converted to O₂ and then through an NO₂ scrubber to remove the NO₂ produced in reaction (1). After passing through the scrubbers the air is pulled into the Total Flow Pump and then vented into the instrument case.

Ozone is produced by pulling ambient air through a chamber containing a low pressure mercury lamp. The lamp has a fused silica window that passes highly energetic atomic emission near 185 nm in addition to the resonant emission at 254-nm. The wavelengths near 185-nm are absorbed by molecular oxygen (O₂) to produce oxygen atoms (O). Those oxygen atoms rapidly attach to O₂ via a termolecular reaction to form O₃.

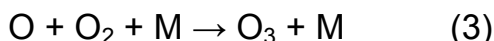
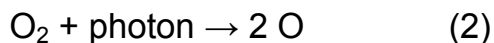

Here, the photon has a wavelength near 185 nm, and M is any air molecule, principally N₂, O₂, Ar and H₂O. The molecule M catalyzes the combination of O and O₂ by removing excess relative translational energy. The flow rate of ozone/air and thus the ozone concentration is controlled by the Ozone Needle Valve. Flow rates and the actual ozone concentration produced are measured in a cycle at the beginning of an analysis by modulating the Ozone Solenoid Valve. This valve either allows the ozone/air mixture to enter the stream of air being analyzed or diverts it to an ozone scrubber.

For the measurement of ozone reagent concentration, the intensity of light at the Detection Cell photodiode is measured in NO-scrubbed sample air that has no ozone added (I_o) and in NO-scrubbed sample air that has ozone added (I). The ozone concentration is given by the Beer-Lambert Law:

$$C_{O_3} = \frac{1}{\sigma l} \ln\left(\frac{I_o}{I}\right) \quad (4)$$

where l is the path length (15 cm) and σ is the absorption cross section for ozone at 254 nm ($1.15 \times 10^{-17} \text{ cm}^2 \text{ molecule}^{-1}$ or $308 \text{ atm}^{-1} \text{ cm}^{-1}$), which is known with an accuracy of approximately 1%. The concentration of ozone reagent is measured each time the instrument is turned on and can be re-measured at any time by briefly pressing the select switch on the front panel. As discussed below, one can also schedule measurements and readjustments of the Total Flow rate and ozone concentration. Reagent ozone is measured to be certain that sufficient ozone is present to cause nearly complete reaction with NO in the sampled air and for the purpose of making a small correction for incomplete reaction. After an ozone measurement and adjustment cycle, the instrument automatically enters NO Measurement Mode and continues to measure NO until 1) the instrument is powered off, 2) the operator uses the select button to re-measure and adjust ozone, or 3) a scheduled ozone measurement occurs.

NO is measured by modulating the NO Solenoid Valve. A low-pressure mercury lamp is located on one side of the absorption cell, and a photodiode is located on the opposite side. The photodiode has a built-in interference filter centered on 254 nm, the principal wavelength of light emitted by the mercury lamp. Shorter wavelengths of light that could produce ozone are absorbed by the low-grade quartz envelope of the lamp itself and by the window of the detection cell, which passes 254-nm but not 185-nm light. The state of the NO Solenoid Valve is switched every 10 seconds in order to measure light intensities for sample air, I , and scrubbed sample air, I_o . The values of I and I_o

are used to calculate the concentration of NO in the original air sample by equation 5:

$$C_{NO} = \frac{1}{\sigma l} \ln \left(\frac{I}{I_o} \right) \quad (5)$$

Note that because ozone decreases when NO is present, the log term is inverted as compared to the normal writing of the Beer-Lambert Law, with I in the numerator and I_o in the denominator.

A correction is made for the small amount of dilution of the NO concentration by the added ozonized air, as shown in equation 6:

$$(C_{NO})_{corrected} = \frac{F_{total}}{F_{total} - F_{ozone}} (C_{NO})_{measured} \quad (6)$$

Where $F_{total}/(F_{total}-F_{ozone})$ is the correction factor (typically less than 5%) for dilution of the sample gas by the addition of ozone/air to the Detection Cell.

Application of equations 4 and 5 give ozone and nitric oxide concentrations, C, in units of molecules/cm³. The pressure and temperature within the absorption cell are measured using miniature sensors in order to calculate the total concentration of gas molecules. This allows nitric oxide and ozone concentrations to be expressed as mixing ratios in parts-per-billion by volume (ppb):

$$X(ppb) = C \left(\frac{T(K)}{273.15} \right) \left(\frac{1013.25}{P(mbar)} \right) 10^9 \quad (7)$$

Note that the abbreviations ppb and ppm refer throughout this manual to volume/volume or mole/mole ratios.

Finally, a small correction (~1%) for incomplete reaction is made to the measured NO concentration based on the reagent ozone concentration and reaction time (determined by total volumetric flow rate and reactor volume).

In principle, the measurement of ozone by UV absorbance requires no external calibration; it is an absolute method. However, non-linearity of the photodiode response and associated electronics can result in a small measurement error. Therefore, each Nitric Oxide Monitor is itself calibrated

against a nitric oxide standard gas, the concentration of which is periodically verified by a 2B Technologies Nitric Oxide Calibrator, whose calibration is traceable to a NIST standard. The corrections for offset and slope are recorded in the instrument Birth Certificate and on a calibration sticker that can be viewed by removing the top cover of the instrument. These calibration parameters are entered into the microprocessor prior to shipment. It is recommended that the instrument be returned to 2B Technologies for cleaning of the flow path, replacement of chemical scrubbers and recalibration at least once annually.

NITRIC OXIDE MONITOR SPECIFICATIONS

Power Requirements 11-14 V DC, nominally 0.9 A at 12 V, 11 watt

Dimensions..... 5.3" x 8.3" x 13.3"

Weight 8.2 lbs (3.7 kg)

*Precision (10-s measurements)** higher of 2.5 ppb or 2%

*Precision (1-min averaging)** higher of 1 ppb or 1%

Accuracy..... higher of 2.5 ppb or 2%

Data Transmission..... 4800 baud, 8 bits, no parity, 1 stop bit

2. OPERATION

Please read all the following information before attempting to install the Nitric Oxide Monitor. For assistance, please call 2B Technologies at (303)273-0559 or email techsupport@twobtech.com.

NOTE:

Save the shipping carton and packing materials that came with the Nitric Oxide Monitor. If the Nitric Oxide Monitor must be returned to the factory, pack it in the original carton. Any repairs as a result of damage incurred during shipping will be charged.

Shipping Box Contents

Open the shipping box and verify that it contains the following:

1. Model 410 Nitric Oxide Monitor
2. 110-240V AC 50-60Hz Power Adapter
3. Cigarette Lighter Adapter
4. Battery Wire Connector
5. Serial Port Cable
6. Zeroing Cartridge
7. CD Containing Nitric Oxide Manual
8. Birth Certificate and Calibration Data

If anything is missing or obviously damaged, contact 2B Technologies immediately.

Pre-Operation Flow Settings of the Nitric Oxide Monitor

The model 410 Nitric Oxide Monitor has three independent flows, which need to be verified and adjusted before operating the instrument. The three volumetric flow rates measured and independently adjusted are:

Sample Flow Rate: (800-1200 cm³/min) The flow rate into the sample inlet of the instrument.

Total Flow Rate: (580-620 cm³/min) The total flow rate of sample gas and ozone/air through the reaction coil and detection cell.

Ozone Flow Rate: (20-30 cm³/min) The flow rate of ozone/air mixed into the Total Flow.

These flow rates are adjusted to be in the ranges specified above at the factory. However, due to changes in altitude and thus pressure, the three flow rates need to be verified and adjusted to be within the specified ranges if necessary. To do this, enter the service menu (**Svc**) by depressing the Select Switch while powering the instrument on. Once in the service menu, select **Tst**, then **Flw**. The LCD will now display the three flow rates. The Total Flow, displayed as **TF**, should be in the range 580-620 cm³/min. This flow can be adjusted by the needle valve located on the back panel labeled "Total Flow". The Ozone Flow, displayed as **O3F**, should be in the range 20-30 cm³/min. The Ozone Flow can be adjusted by the needle valve located on the back panel labeled "Ozone Flow". The sample flow, displayed as **SMPF**, should be in the range 800-1200 cm³/min. This flow can be adjusted with the needle valve in the flow path immediately following the sample pump (pump with orange and black wires) located on the bottom of the instrument and can be accessed by removing the bottom panel of the instrument. Once these flows have been verified and adjusted they should not need to be re-adjusted unless the instruments location changes in altitude. After adjusting the flow, the instrument power should be cycle on and off before proceeding.

Note: While in the flow adjustment menu, the duty cycle of the voltage applied to the Sample Pump is held at 60%, and the duty cycle of the Total Flow pump is 50%. During the Parameter Adjustment Mode, the duty cycles of the pumps are adjusted if the flow rates are out of range.

Operation of the Nitric Oxide Monitor

To operate the Nitric Oxide Monitor, connect it to an external power source and power the instrument on using the front panel power switch. The instrument requires a 12 V DC source, which can be supplied by the 110-220 V AC power adapter provided or an external battery. The power source should be capable of supplying at least 2.5 amperes of current at 12 V (30 watts).

Once turned on, the instrument will display:

2B Technologies
NO 410 Ver x.xx

where "x.xx" is the version number of the firmware installed on the microprocessor. After powering up, the instrument will begin a 20-minute

WARMUP mode. During this period a count down of time in minutes and seconds will appear on the display. If the instrument was previously warmed up, the warmup period can be skipped by briefly pressing (“clicking”) the SELECT switch (black knob on front panel labeled “Select”).

Following warmup, the instrument will enter the **Parameter Adjustment Mode**, during which time the flow rates and ozone reagent concentration are adjusted to be in range. The Total Flow rate and Sample Flow rate will first be displayed briefly on the LCD while they are being adjusted in real time. Next, the ozone concentration will be displayed on the LCD, along with the Total Flow rate, temperature and pressure every 10 seconds; for example:

O3= 4537 F= 610
T= 28.2 P= 997.7

where ozone concentration is in ppb, F is the Total Flow rate in cm³/min volumetric, T is the temperature in the chosen units (°C or K) and P is the pressure in the chosen units (Torr or mbar).

For accurate measurements of NO with the greatest precision, the total flow rate should be in the range 550-650 cc/min and the ozone concentration should be in the range 3000-5000 ppb. During Parameter Adjustment Mode, and if the instrument also is set to Auto Mode, the instrument will attempt to adjust the sample flow to 900-1100cc/min, total flow to 580-620cc/min and ozone concentration to the narrower range of 3800-4200 ppb by pulse width modulation of the sample flow pump, total flow pump and ozone source lamp.

The first three ozone measurements are spurious and will be reported as the ozone value previously stored in memory. After every set of 3 ozone measurements, the ozone source intensity is adjusted in an attempt to bring the ozone concentration into the range 3800-4200 ppb. Once the ozone concentration is both in range and stable, the instrument will skip to NO Measurement Mode (**NO Mode**). After 30 ozone measurements (5 minutes), the instrument will skip to **NO Mode** even if the ozone concentration is not in range. Also, the user can skip to NO Mode at any time during ozone measurements by momentarily pressing the select switch. When skipping to NO Mode, the most recently measured ozone concentration will be stored in memory and displayed until the Parameter Adjustment Mode is next entered.

In the NO measurement mode, the first five readings are spurious and are reported as 0. After another 5-10 measurements the reported NO

concentrations should be stable and after 20-30 measurements the average standard deviation of ten sequential measurements should be ± 1.5 ppb or better.

Scheduling Ozone Measurement Adjustments

The instrument can be set to readjust (“tweak”) the flow rates and ozone concentration at frequencies of 1 time per day or 4 times per day. To do this, go to the Service Menu by powering the instrument on while depressing the select switch. Choose **Sch** from the Service Menu and set the **O3 Adj Freq** to 0, 1 or 4. When selecting 0, the instrument will return to **Parameter Adjustment Mode** only manually (by a click of the Select switch) or after experiencing a power interruption. When set to 1, **Parameter Adjustment Mode** will be entered every 24 hours following the time this parameter is set. When set to 4, **Parameter Adjustment Mode** will be entered every 6 hours following the time this parameter is set.

Collecting Data over the Serial Port

Measured parameters may be continuously collected on a computer from the serial port of the Nitric Oxide Monitor. To transmit data to a computer over the serial port in real time, connect the NO Monitor to the serial port of the computer using the 9-pin serial cable provided. If your computer does not have a serial port, you can connect via its USB port by use of a serial-to-USB port adaptor. Start your data acquisition software; such as the 2B Technologies Display and Graphing Software (free download from <http://twobtech.com/software.htm>). Optionally, other terminal emulation programs, such as Hyperterminal (included with Microsoft Windows®) or Tera Term Pro can be used. A free download of Tera Term Pro is available at:

<http://hp.vector.co.jp/authors/VA002416/teraterm.html>

In addition to data lines, messages are written to the serial port to describe the functions being performed. A complete Parameter Adjustment Mode cycle followed by output of NO measurements produces the following lines of data, for example:

BEGIN NEW NO PARAMETER ADJUSTMENT

Ozone Flow = 22cc/min

ozone flow rate

Setting total flow rate...

Setting sample flow rate...

Total Flow = 619 cc/min

total flow rate

Sample Flow = 988 cc/min

sample flow rate

S = 1.02, Z = -2, TFcal = 1.12, SFcal = 1.01 *Calibration parameters applied*
Signal Photodiode voltage = 0.98 V *should be in the range 0.7 – 2.0 v*
Lamp Duty Cycle @ 71% *should be less then 75%*
Total Flow Pump Duty Cycle @ 48% *should be 42-90%*
Sample Flow Pump Duty Cycle @ 45% *should be 42-90%*
Automatic control of ozone concentration and Flow Rates *In Auto mode*
Measure Ozone Concentration and Flow Rates *Start ozone measurements*

O3, Temp, Press, Sample_flow, Total_flow, O3_flow *Header for O₃ data stream*
data line 1
data line 2
date line 3
.....
data line 30

Ozone = 4513 ppb *Final measured O₃ concentration*
Total Flow Rate = 630 cc/min *Final measured Total flow rate*
Flow correction factor = 1.03 *Should be in range 1.00-1.10*
Incomplete Reaction Correction Factor = 1.01 *Should be in range 1.00-1.10*
Lamp Duty Cycle @ 71% *Should be in range 50-75%*
Total Flow Pump Duty Cycle @ 48% *Should be in range 42-90%*
Sample Flow Pump Duty Cycle @ 45% *Should be in range 42-90%*

If the ozone concentration remains within the range (3800-4200 ppb) for 3 sequential measurements, the instrument will exit NO Parameter Adjustment Mode and enter NO Measurement Mode. The instrument will then begin measuring NO concentration and write to the serial port:

Measure NO Concentration *Start measuring NO concentration*
O3 Adjust Frequency = 0 times/day *Frequency of auto adjust selected in Svc menu*
Avg: 10 s/rdg *Averaging time selected in Avg menu*

NO, Temp, Press, Sample_flow, Total_flow, O3_flow, Scrubber_temp, O3,
Date, Time, Molly_Status , Heater_Status *Header for NO data stream*
data line 1
data line 2
data line 3
.....

Nitric oxide data will continue to be output until the Select Switch is used to enter the Menu or the Parameter Adjustment mode.

As an example, a typical data line for NO reads:

20.3, 35.3, 836.5, 1084, 603, 21, 100.2, 4190, 21/02/10, 13:16:41, 0, 1

Where:

NO = 20.3 ppb

Cell temperature = 35.3 °C (if °C units have been selected)

Cell pressure = 836.5 mbar (if mbar units have been selected)

Sample Flow Rate = 1084 cc/min (volumetric)

Total Flow Rate = 603 cc/min (volumetric)

Ozone Flow Rate = 21 cc/min (volumetric)

Heated Scrubber Temperature = 100.2 °C

Ozone Concentration = 4190 ppb (measured in Parameter Adjustment Mode)

Date = 21 February 2010

Time = 1:16:41 pm

Molly Status = 0, NO mode on, NO_x and zero modes off

Scrubber Heater Status = 1, Heater on

Using the Menu to Change Instrument Parameters

The Menu may be accessed to log and transmit data, choose the averaging time, change the calibration parameters, turn the backlight of the LCD on and off and choose units for pressure and temperature. The Service Mode may be accessed by holding down the select knob while powering the instrument. Use this mode to test the lamp, output raw data, turn the automatic parameter adjustment mode on and off, and schedule automatic parameter adjustment.

The **Menu** is accessed by using the Select switch on the front panel. Navigation within the **Menu** is summarized in Fig. 2. Momentary depressions (“clicks”) of the Select switch change the instrument mode from **Warmup** to **Parameter Adjustment Mode** to **NO Mode** and back to **Parameter Adjustment Mode**. Depressing the Select switch for a time longer than about 1 second accesses the **Menu**. Within the **Menu**, rotating the select switch moves a blinking cursor back and forth between the four submenus, **Dat**, **Avg**, **Cfg** and **Mol**. To enter a submenu, position the cursor under the first letter of the submenu name and “click” (quickly press and release) the Select switch. To move up one level in the menu, move the underline cursor to the left arrow (←) and click the Select switch.

In general, horizontal navigation within the menu and submenus is achieved by rotating the Select switch, clicking on a submenu title allows

movement downward in the menu, and clicking on the return symbol (left arrow, ←), provides movement up one level in the menu.

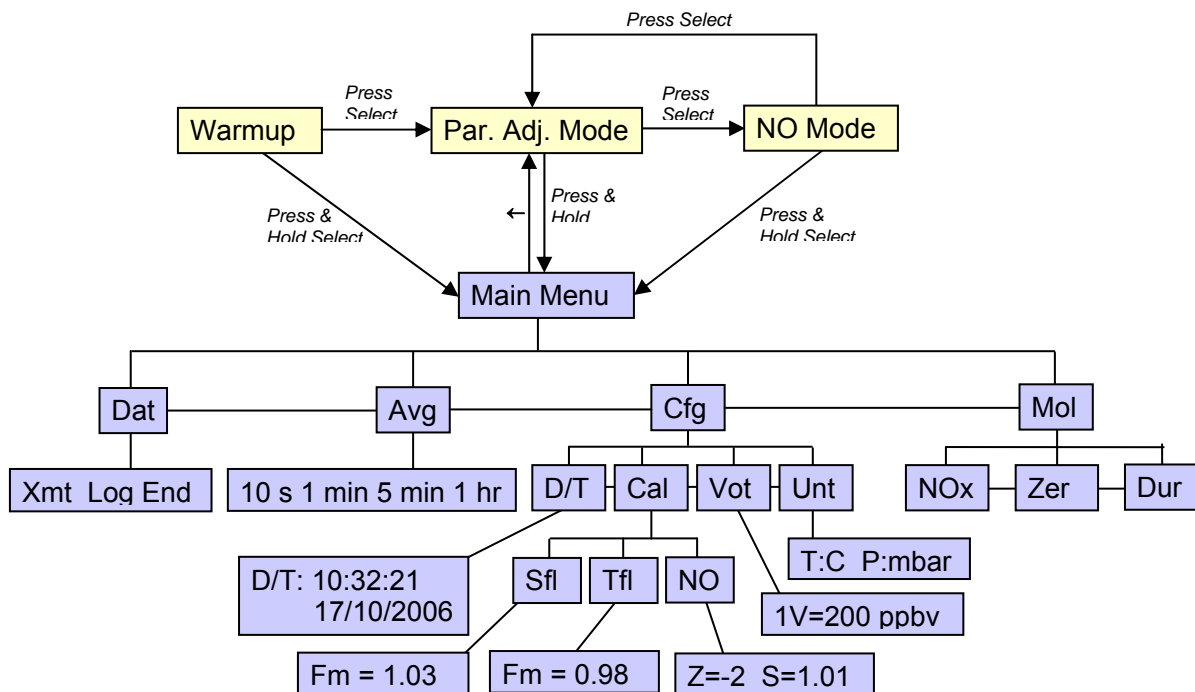

Figure 2. Navigation chart for the NO Monitor menu.

Data Averaging and Data Logging Using the Menu

The NO Monitor reports new measurements of the NO concentration every 10 s. You may choose to average these data within the instrument for periods of 1 min, 5 min and 1 hour. Also, data lines may be stored in the instrument's internal data logger. Up to 16,383 data lines containing the log number, NO mixing ratio, internal temperature, internal pressure, total flow rate, date and time may be stored in internal memory, corresponding to an operational time of 1.9 days. Averaging times of 1 min, 5 min and 1 hr also may be selected from the menu, thereby allowing the instrument to operate for 1.6 weeks, 1.9 months and 1.9 years, respectively, before filling the memory. For virtually unlimited data storage, we recommend the flash memory option, which is also available as an upgrade.

To Log Data

To reach the **Menu**, hold in the Select button until **Menu** is displayed. Then release the button. The panel will now display:

Menu
Dat Avg Cfg Mol ←

where **Dat**, **Avg**, **Cfg** and **Mol** are submenus that may be selected. A blinking cursor will show across the **D** of the **Dat** submenu. The Select switch may be rotated clockwise or counterclockwise to position the cursor over the first letter of one of the other submenus. To select a particular submenu, move the cursor to the first letter of a submenu and click the Select switch. To exit the menu and begin making measurements again, select and click on the left arrow (←).

Select the **Dat** submenu from the Main Menu using the Select button. The display will now show:

Data Menu
Xmt Log End ←

To start logging data, rotate the Select switch to move the cursor to the first letter of **Log** and click to select the logging mode. You will then be asked whether you want to overwrite the data stored in the logger:

Overwrite Data?
No Yes ←

If you select **Yes** and start logging, all data previously stored in the logger will be irretrievably lost. If you have data in the logger that you want to keep, be sure to download it using the **Xmit** function before starting logging. If you are ready to start logging, then select **Yes** by positioning the cursor and clicking. Either selection will return you to the **Main Menu**. To start data acquisition, select ← and click.

The NO Monitor will then alternately display: 1) the O₃ mixing ratio, internal temperature and internal pressure and 2) the NO mixing ratio and log number. For example, the display might read:

O3= 4135 F= 603
T=25.6 P=989.7

where the ozone concentration most recently measured is 4135 ppb (4.135 ppm), the total volumetric flow rate is 603 cc/min, the cell temperature is 25.6 °C (if °C units are selected), and the cell pressure is 989.7 mbar (if mbar units are selected). After 5 seconds (midway between 10-s measurement cycles), as an example, the display will be replaced by:

NO= 56.7 ppbv
Log= 193:0

where **NO** is most recently measured NO concentration, and the log number is 193.

If averaging has been selected, the ozone value (**O3**) will be replaced by **AVG**, which is the most recently calculated average value of NO, and the first screen will read for example:

AVG= 57.3 F= 603
T=25.6 P=989.7

The second screen (5 seconds later) will display for example:

NO= 56.7 ppbv
Log= 193:4

where NO is the most current 10-s measurement of NO. Again 193 refers to the most recent log number. The “4” in 193:4 refers to the number of 10-s data points that have been measured so far for inclusion in the next average to be displayed and logged. If 10-s averaging is used (i.e., no averaging), this number will always be 0. If 1-min averaging is used, this number will increment from 0 to 5; for 5-min averaging, the number will increment from 0 to 29; and for 1-hr averaging, it will increment from 0 to 359. This number is displayed so that the user will know how many more 10-s measurements need to be made before a new average is displayed and logged.

If there is a power failure while the instrument is in the logging mode, when power is restored the instrument will go into Warmup mode followed by Parameter Adjustment Mode followed by NO Mode, and logging of data will resume.

Note: Once logging has started, you should not enter the menu, except to end logging. In particular, you should not change the averaging time during logging.

To Stop Logging Data

Hold the Select button in to obtain the **Menu**. Go to the **Dat** submenu by clicking on **Dat**. Choose and click on the **End** function. This will end data logging. You may now transmit the data to a computer by clicking on **Xmt** (see below). You may transmit the data as many times as you want. Alternatively, you may return to the **Menu** by clicking on ←. The stored data will reside in memory (even when new measurements are being made) and can be transmitted using the **Xmt** function at a later time. However, all stored data are lost once logging is started again using the **Log** function. Thus, you should always transmit your data to a computer before restarting logging.

If you fail to **End** logging prior to transmitting the data using the **Xmt** function, the instrument will automatically execute the **End** function for you before transmitting the data.

To Transmit Logged Data to a Computer Using the Serial Port

Connect the serial port of the instrument to the serial port of your computer using the cable provided. Start your data acquisition software; such as the 2B Technologies Display and Graphing Software, which can be downloaded at:

<http://twobtech.com/software.htm>

Alternatively, Hyperterminal can be used (available on most Windows[®] platforms, usually in Start/All Programs/Accessories/Communications/Hyper Terminal) or Terra Term Pro, which can be downloaded at:

<http://hp.vector.co.jp/authors/VA002416/teraterm.html>

For more details on the use of Tera Term Pro and Hyperterminal, see our Tech Note #007 here:

http://www.twobtech.com/tech_notes/TN007.pdf

Hold down the Select button to obtain the **Main Menu**. Go to the **Dat** submenu by clicking on **Dat**. Next, click on **Xmt**. The message “Logged Data” will be written to the serial port, followed by a carriage return and all of the lines of logged data. After all data are transmitted, the message “End Logged Data” and a carriage return are written. After transmission is complete, you can return to any position in the menu or resume NO measurements. The logged data continues to reside in memory and be available for transmission until a new data log is started.

To Average Data

Hold down the Select button to obtain the **Menu**. Select and click on **Avg** to obtain the **Avg** menu:

Avg Menu
10s 1m 5m 1h ←

Use single clicks to move the cursor to **10s**, **1m**, **5m** or **1h** for averaging times of 10s (no averaging), 1 min, 5 min or 1 hr, respectively. Then click on the averaging time you want to use. To return to the Main Menu, click on ←. To exit the Main Menu and start acquiring data, click on ← again.

While in averaging mode, the current 10-s measurement is displayed alternately with the average value, as discussed above. Averaged data may be logged, thereby greatly extending the length of time that the data logger can be used.

To Change the Calibration Parameters

The NO Monitor is calibrated at the factory, and calibration factors are entered to make the instrument read accurately over the range 0 to 1,000 ppb. The user may wish to recalibrate the instrument from time to time and change the calibration parameters. However, it is recommended that the NO Monitor be returned to 2B Technologies for recalibration at least once per year.

To change the calibration parameters, select **Cfg** from the **Menu** and **Cal** from the **Cfg** submenu. The following submenu with the values of the current calibration parameters will then appear:

Cal Menu
Sfl Tfl NO ←

The parameters **Sfl** and **Tfl** are calibration factors for the two flow meters to make them read correctly in terms of volumetric flow. These parameters are set in the factory and should not be changed unless you have independently calibrated the flow meters. Factory values of the calibration parameters Sfl and Tfl are recorded in the instrument's Birth Certificate are typically in the range 0.8-1.2. Selecting **NO** allows one to enter a submenu for entering the slope (S) and offset (Z) calibration parameters. For example, the **NO** submenu might read:

Cal NO Menu
Z= -2 S= 1.02 ←

Here Z is the additive offset correction applied (in this case -2 ppb) and S is the multiplicative slope correction factor applied (in this case 1.02) to the raw data. For example, if the instrument reads an average of 3 ppb when sampling NO-scrubbed air (and with the calibration factors set to Z=0 and S=1.00), the value of Z should be set to -3. If after correction for the zero, the instrument consistently reads 2% low for a NO calibration standard, the value of S should be set to 1.02.

A few words of caution: Compressed air cylinders often contain traces of NO, so it is necessary to use an external NO scrubber when measuring the zero of the instrument. Also, calibration standards frequently decline in concentration with time and may provide inaccurate results.

When the **Cal Menu** first appears, an underline cursor will be beneath the **Z**. Depressing the Select switch will change this cursor to a blinking dark cursor that covers the **Z**. When the cursor is blinking, you can change the value of the selected parameter by rotating the Select switch (clockwise to increase and counter-clockwise to decrease). Once the desired value is chosen, click the Select switch to store that value in memory; the cursor will now return to an underline. You may now move the underline cursor to **S** by rotating the Select switch and click on **S** to enable change of the slope calibration parameter. To exit the **NO** calibration menu move the underline cursor to ← and press the Select switch.

To use the Analog Output

An analog output is provided via a BNC connector at the back of the instrument for those who want to record their NO/NO_x concentration data with a chart recorder or external logger. The full scale of the analog output is 2.5 V. To change the analog output voltage scaling factor, select **Vot** from the **Cfg** Menu:

VOUT Menu
1V=000100 ppb ←

In this example, the output scaling factor is set as 1 Volt = 100 ppb. Since the maximum output voltage is 2.5 V, the maximum output concentration in this case is 250 ppb, and 1 ppb will provide an output of 2.5 mV. You can use the select switch to change the scaling factor to the value of your choice by selecting and changing the individual digits in the scaling factor.

To Set the Time and Date

From the **Main Menu**, select the **Cfg** submenu. Next, select the **D/T** submenu. The display will read, for example:

D/T: 14:32:21 ←
17/10/2006

meaning that it is 21 seconds after 2:32 p.m. on October 17, 2006 (military time and European date). To change a number in the date and time, rotate the Select switch to underline the numeral you want to change. A single click then causes a blinking cursor to cover that numeral. The number can then be changed by rotating the Select switch. Once the number is correct, click on the Select switch to turn off the blinking cursor. You may now rotate the Select switch to choose another numeral to change. Once the time and date is correct, clicking on ← will set the internal clock to that time and return the display to the **Cfg** menu. As in setting a digital watch, the seconds should be set in advance of the real time since the clock starts to run again only when the set time is entered; in this case by clicking on ←.

To Change the Units for Internal Temperature and Pressure

From the **Cfg** menu, select **Unt** to give the following submenu, for example:

Units Menu
T:C P:mbar ←

Rotating the Select switch will cycle the underline cursor between temperature (**T**) and pressure (**P**). Temperature units may be selected as either Kelvin (**K**) or Celsius (**C**) by first clicking to obtain the blinking cursor and then rotating the Select switch to obtain the desired units. Pressure units may be selected as either **torr** or **mbar**. A click on ← returns the display to the **Cfg** menu.

Mol Menu

The **Mol** menu is used in conjunction with the model 401 NO₂ (molybdenum or “molly”) converter. Details of this menu can be found in the 401 NO₂ converter user manual. If the Model 410 is not being used with a 401, this menu should remain unchanged and the molly status on the data line in NO mode should read 0.

Service Menu

The **Svc** menu is reached by holding in the select switch while powering on the instrument:

Svc Menu
Adm Tst Aut Sch ←

An Administrative Mode may be selected under the **Adm** submenu. In this mode, the serial output of the instrument displays raw data for the detection cell. When in Administrative Mode, a typical serial output line might read:

50.6, 55.6, 33.3, 836.6, 1092, 598, 22, 97.5, 4190, 10/09/06, 14:52:10, 0, 1

Where:

NO raw measurement = 50.6 ppb

NO measurement = 55.6 ppb

The NO measurement includes corrections for the sample dilution by the ozone flow, incomplete reaction of NO with ozone, a complex averaging process of the raw data, and the slope and offset calibration factors.

Cell temperature = 33.3 °C (if °C units have been selected)

Cell pressure = 836.6 mbar (if mbar units have been selected)

Sample Flow Rate = 1092 cc/min (volumetric)

Total Flow Rate = 598 cc/min (volumetric)

Ozone Flow Rate = 22 cc/min (volumetric)

Heated Scrubber Temperature = 97.5 °C

Ozone Concentration = 4190 ppb (measured in Parameter Adjustment Mode)

Date = 10 September 2006

Time = 2:52:10 pm

Molly Status = 0: NO mode on, NO_x and zero modes off

Scrubber Heater Status = 1, Heater on

Test Menu

The **Tst** menu allows the user to determine and adjust the instrument flow rates and run a diagnostic lamp test.

Lamp Test

A diagnostic lamp test is provided by selecting **Lmp** in the **Tst** submenu of the Service menu. When first entering the **Lmp** submenu, the voltage measured by the photodiode is displayed. For best performance this voltage

should be in the range 0.7-2.0 volts. For detector voltage less than about 0.7 volts, the data may be noisy due to insufficient light intensity to make precise measurements. If the voltage is zero, the lamp is not ignited and is either burned out or not receiving 5 V from the circuit board. For voltages above 2.0 volts, the A/D converter is saturated and the measured ozone and NO concentrations will be spurious. This could happen if the instrument is very hot so that the lamp output is too bright.

Immediately following display of the detector voltage, the instrument starts measuring an “effective” NO concentration without switching the solenoid valve on and off. This is an electronic zero and should after a few readings settle down to \pm a few ppb. If the value is outside the range -10 to +10, the instrument may not be operating correctly. The display also gives a standard deviation of the electronic zero. For best measurement precision (low noise), the average standard deviation should be no greater than ± 3 . The initial lamp voltage and subsequent “zero” measurements, along with the standard deviation of the lamp, will be transmitted on the RS232 line to observe the data on a computer.

To exit the **Lmp** test mode, hold in the Select switch and release to return to the **Tst Menu**.

Flow Test

The Sample, Total and Ozone flow rates can be checked and adjusted if needed by selecting **Flw** in the **Tst** submenu of the Service Menu. Once there, the total flow/ozone flow pump will be set to a 50% duty cycle and the sample flow pump duty cycle will default to 60%. The LCD will display the three volumetric flow rates. **O3F** is the ozone flow and should be in the range 20-30 cc/min. The ozone flow can be adjusted by the needle valve on the back panel of the instrument labeled “Ozone flow”. The Total Flow rate, **TF**, is the flow rate through the reaction coil and detection cell. This flow should be in the range 550-650 cc/min. The Total Flow rate can be adjusted by the needle valve on the back panel labeled “Total Flow”. Opening this needle valve allows extra air to enter into the pump and thus reduces the Total Flow. To reduce the Total Flow, partially open the needle valve by turning it counter clockwise. To increase the Total Flow partially close the needle valve by turning it clockwise. Because the ozone flow and total flow are pulled by the same pump, the ozone flow may change slightly when adjusting the Total Flow. It is recommended that the Ozone Flow be rechecked once the Total Flow is set. The Sample Flow rate, **SMPF**, is a measurement of the air flow being sampled into the instrument through the inlet at the back. This flow should be at least 900 cc/min to assure that there is an adequate overflow at the overflow tee (see Fig.

1, page 2); a flow of up to 650 cc/min is drawn from this overflow tee. If the NO Monitor is being used with a Model 401 NO₂ converter, the sample flow needs to be in the range 900-1100 cc/min to assure adequate residence time within the molly converter and can be adjusted by an internal needle valve. To access this needle valve remove the bottom cover of the instrument; the Sample Flow needle valve is attached to the outlet of the Sample Flow Pump. **Do not completely close this needle valve.** Doing so will cause damage and possibly failure of the sample flow pump. Ideally, this needle valve will be open as much as possible while keeping the sample flow in range.

Automatic and Manual Modes

The **Aut** (for “automatic”) submenu is used to turn automatic control of flow rates and ozone concentration on and off. For normal operation the **Aut** parameter should be set to **On**. If set to **Man** (“manual”), the flow rates and ozone source intensity will not be adjusted during Parameter Adjustment Mode. Manual mode is used for diagnostic purposes only.

Schedule Parameter Adjustment Mode

The **Sch** (for “schedule”) submenu is used to set the frequency of automatic entry into the Parameter Adjustment Mode where the Sample Flow rate, Total Flow rate and ozone concentration are adjusted. Use of both of these submenus is discussed earlier in this manual.

3. MAINTENANCE/TROUBLESHOOTING

The Model 410 Nitric Oxide Monitor is designed to be as maintenance free as possible. Components that require routine maintenance include the ozone and NO scrubbers, which should be changed at least once every six months of operation and the air pumps. The air pumps have a rated lifetime of 5000 hours (~7 months) of operation and will need to be replaced when the flow rates can no longer be brought into range or the pumps fail due to burned out motors or split diaphragms. Operation with a high restriction on the sample inlet will greatly reduce the lifetime of the Sample Pump, and operation at low temperatures reduces the lifetimes of both pumps. The instrument is designed so that pump replacement is relatively easy.

If the instrument fails to operate correctly, common problems can be identified and corrected using Table I below. Also, please feel free to contact us at any time by submitting a Tech Support ticket at www.twobtech.com/techsupport. If the problem cannot be corrected on site, the instrument may be returned to 2B Technologies for service. Please phone or email in advance for shipping instructions. Often, the problem with the instrument can be diagnosed over the phone, by email or through Tech Support ticketing, and corrections or repairs made without returning the instrument to the factory. Before contacting 2B Tech, it is helpful if you can make a few observations. These include:

- 1) What are the ozone concentration, NO concentration, temperature, pressure and flow rate displayed by the instrument on the front panel?**
- 2) What is the voltage output for the photodiode?** These should fall in the range 0.7 to 2.4 V. Enter the Service Mode by pressing the select knob while powering the instrument. The select **Tst**, then choose the **Lmp** submenu. The voltages of the photodiode will be briefly displayed. The instrument will then measure the electronic offsets and standard deviations of the detection cell. The offsets should be near zero and the standard deviations (preceded by “±”) should be less than 3 ppb.
- 3) Is air being drawn into the instrument?** Briefly hold your finger over the air inlet to determine whether there is suction.
- 4) What is the average value of NO measured when the NO scrubber is attached to the inlet (i.e., the instrument zero)?**

-
- 5) **How noisy is the instrument?** Calculate the standard deviation of 10 sequential measurements with the external NO scrubber in place.
 - 6) **If possible, collect data from the serial port for both the Parameter Adjustment Mode and NO Measurement Mode and submit a tech support ticket at www.twobtech.com/techsupport or email us at techsupport@twobtech.com with an explanation of the problem you are experiencing with the instrument.**

If you feel comfortable working on the instrument, additional useful information can be provided by removing the top and bottom instrument covers. Annotated photographs of the inside of the instrument case and of the circuit board are given below. With the top and bottom removed power up the instrument. Useful questions that you can quickly answer once the top and bottom covers are removed are:

- 1) **Is the ozone source lamp ignited?** There should be a purple glow coming from the tubing attached to the ozone source located in the top of the instrument.
- 2) **Is there an overflow of air?** Place your finger on the overflow tee located in the bottom of the instrument and determine whether air is going into (incorrect) or out (correct) of the overflow tee.
- 3) **Is there power to the board?** Measure the dc voltage on the power inlet connector shown in Figure 3-3. It should be close to 12 V.

The figures following Table I provide a “guided tour” of the instrument so that critical components and connectors may be easily identified. A list of serviceable parts is provided in Section 4 at the end of this manual.

Table I. *Troubleshooting the Nitric Oxide Monitor for performance problems.*

Problem/symptom	Likely cause	Corrective action
<i>Instrument does not turn on.</i>	Power not connected properly or circuit breaker tripped.	Check to see that the power adapter is supplied with 110 or 220 v ac power and that 12 v dc is reaching the circuit board.
<i>Display is blank or nonsense.</i>	Bad connection of display to circuit board.	Remove top cover and reconnect display to circuit board. Check solder connections to display.
<i>Cell temperature reads low by several 10's of degrees.</i>	Absent or loose connection of temperature probe cable to circuit board.	Remove top cover and check attachment of temperature sensor connector to circuit board.
<i>Readings are noisy with standard or on external scrubber with standard deviations greater than 3.0 ppb.</i>	Lamp is not on.	Check lamp connection to circuit board. Remove bottom cover, turn instrument on, and visually check to see that lamp turns on within a few seconds after the power switch is turned on. Return instrument for lamp replacement if lamp does not light.
	Lamp output is weak.	Measure reference and sample photodiode using Svc submenu. If either voltage is less than 0.9 V DC, contact 2B Tech for lamp replacement.
	Excessive vibration.	Provide additional

		vibration insulation for the instrument such as a foam pad.
Select switch does not work.	Cable not properly connected between select switch and circuit board.	Remove top cover and reconnect select switch cable to circuit board.
Serial port does not work.	Cable not properly connected between serial port 9-pin connector and circuit board. Wrong serial cable used. Wrong baud rate is used.	Remove top cover and reconnect serial port cable to circuit board. A “straight through” serial cable is provided. Some data collection devices require a “cross over” cable in which pins 1 and 3 are exchanged between the two ends of the cable. Use a “cross over cable or additional connector that switches pins 1 and 3. Make sure the baud rate of your data collection device is set at 4800.
Required calibration parameters are excessively large when calibrated using a reference gas standard.	Standard incorrect. NO scrubber is contaminated or scrubbing capacity is depleted.	NO standards are notoriously unstable and decrease in concentration with time. Try using another standard. Replace ozone scrubber. Be sure to use an inlet filter to remove particulate matter.

	Connecting tubing and/or absorption cells are contaminated.	Rinse cells and tubing with methanol and dry with zero air. Replace internal tubing with ¼" O.D., 1/8" I.D. Teflon-lined Tygon® tubing (or silicone tubing where not in sample flow path).
<i>Instrument always reads close to zero for NO concentration.</i>	Solenoid valve cable is not properly connected to circuit board.	Reattach solenoid valve cables to circuit board.
<i>Instrument always reads close to zero for NO concentration.</i>	Solenoid valve cable is not properly connected to circuit board.	Reattach solenoid valve cables to circuit board.

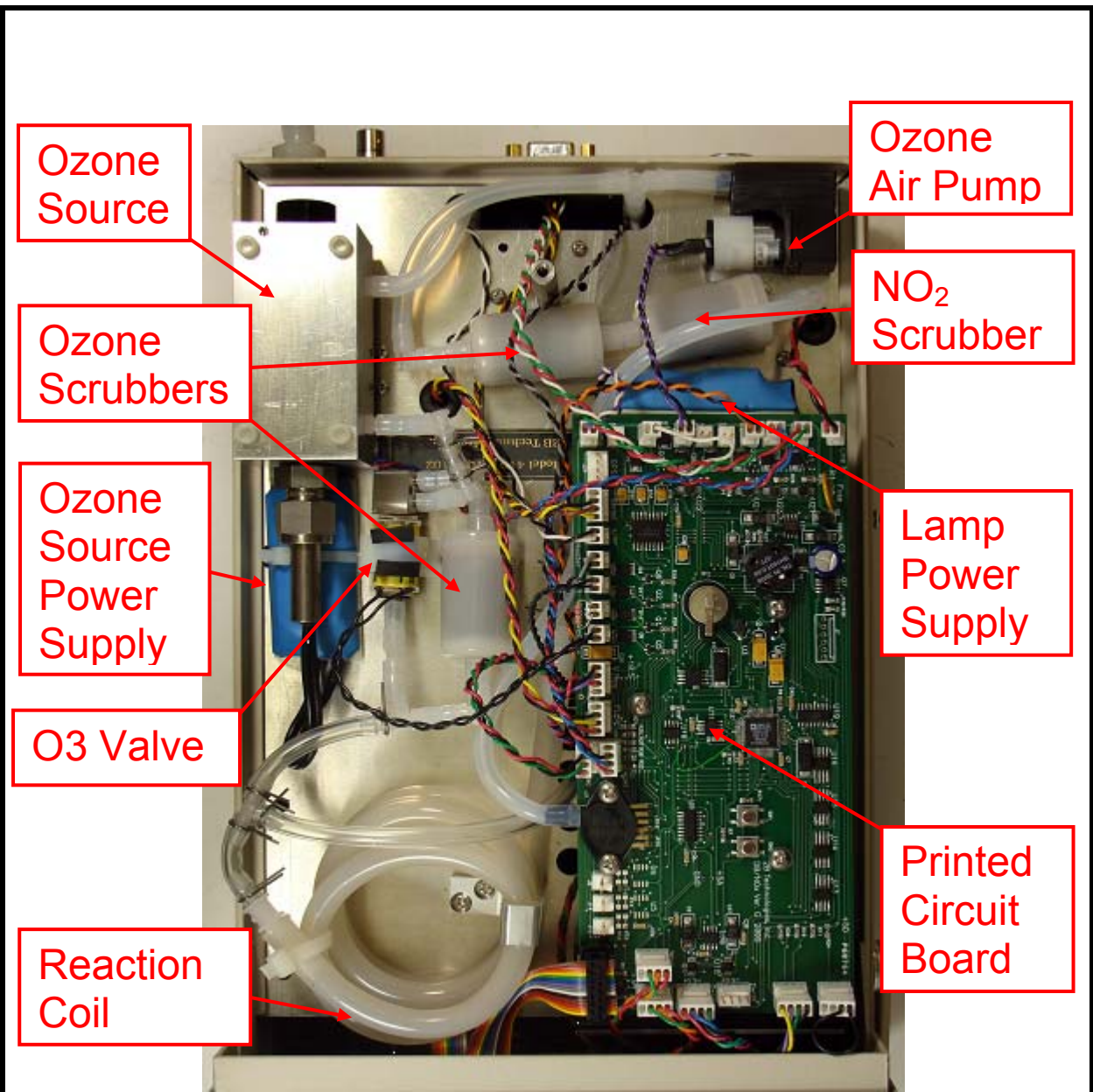

Figure 3-1. Top View of NO Monitor with cover removed. Optical bench is beneath the printed circuit board.

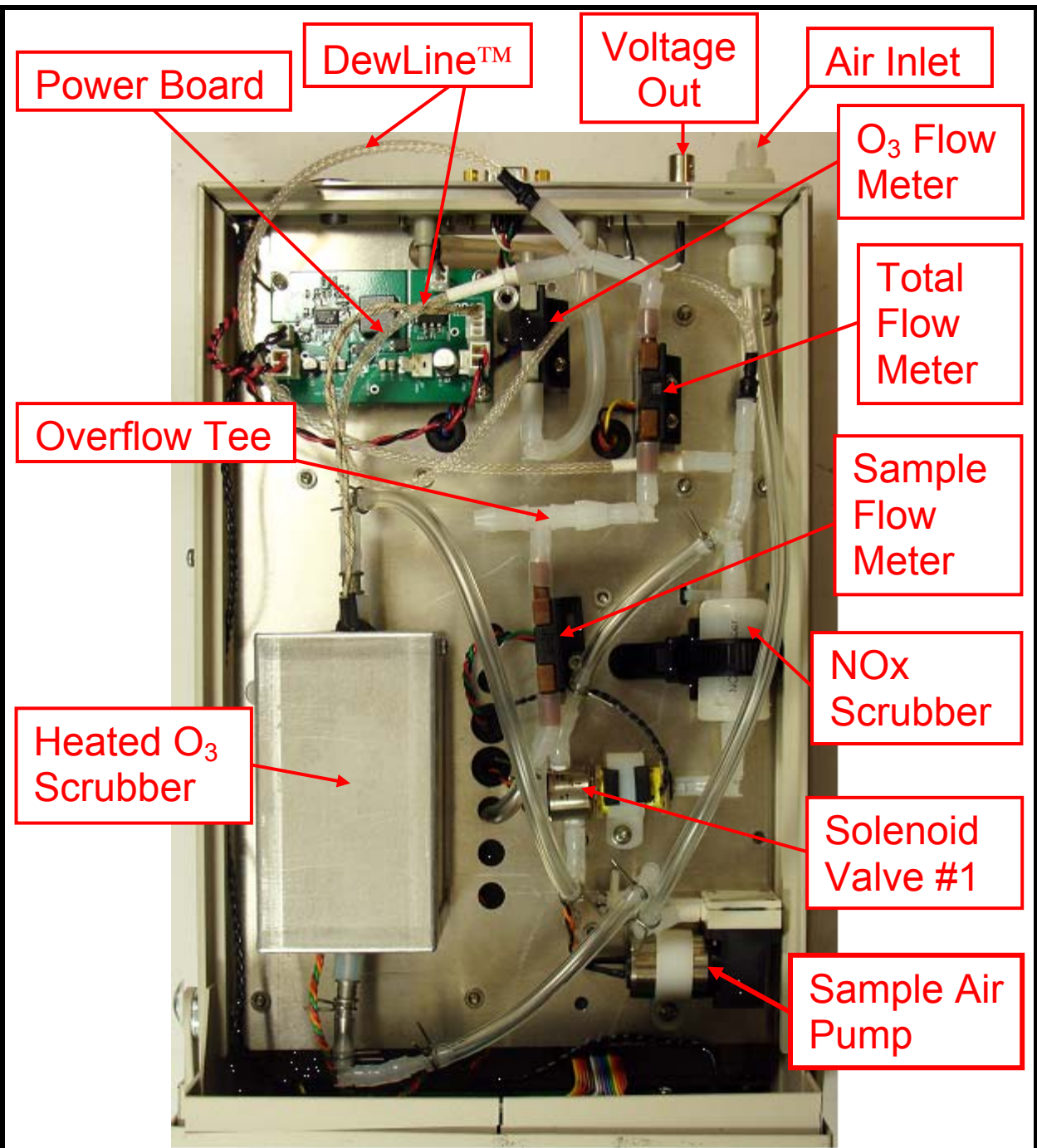

FIGURE 3-2: Bottom view of Nitric Oxide Monitor with cover removed.

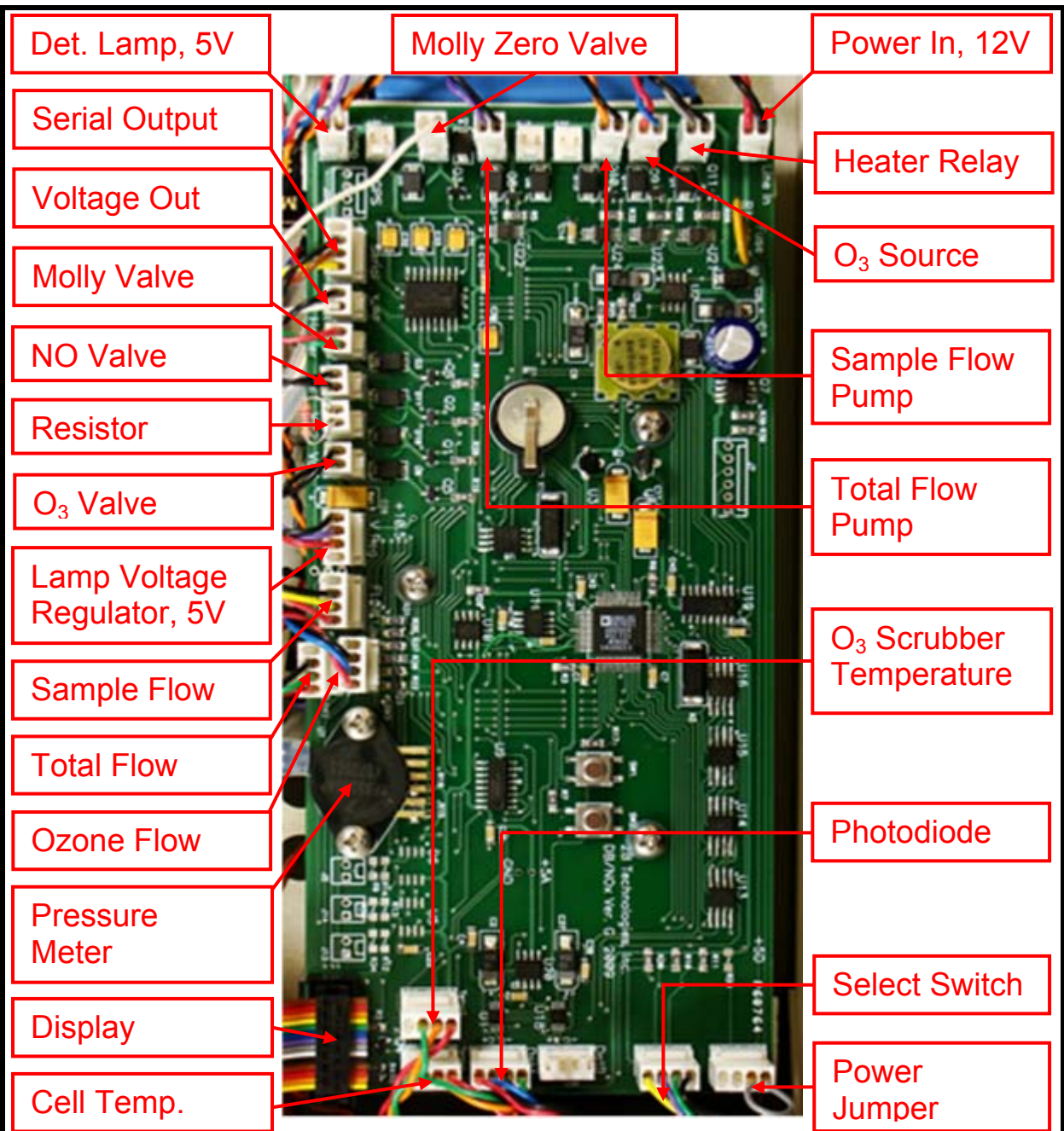
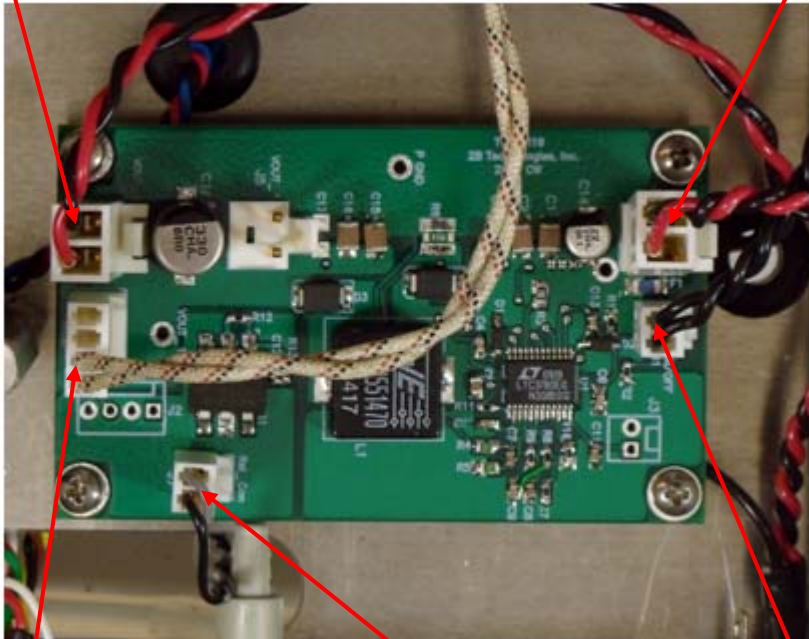

FIGURE 3-3: Printed Circuit Board. (Individual Instruments may vary.)

12 V Out to PCB

Voltage In



10 Watt Heater for
Ozone Scrubber

Relay Control for
Heater

On/Off Switch

FIGURE 3-4: Power Board

4. PARTS LIST

The following list includes those parts that are user serviceable.

<u>Part Number</u>	<u>Description</u>
NOSCRBINT	NO scrubber (internal)
NOSCRBEXT	NO scrubber (external)
NOOZSCRBL	NO scrubber, large
NOOZSCRBS	NO scrubber, small
NOLAMP	Lamp and cable
NOVLV	Solenoid valve
NOBRD	Circuit board without microprocessor
NODSP	LCD display and cable
NOPUMPS	Air sampling pump (Air Pump #1)
NOPUMPI	Air Pumps #2 and #3
NOPDASSY	Photodiode assembly and cable
NOCELL	Absorption cell
NOPWRASSY	Power connector/circuit breaker assembly
SERCABL	Serial port cable (to computer)
SERCON	Serial port connector and cable
NO110ADP	110 V AC adapter
PWRWIR	Bare wire power cable
12VADP	12 V DC cigarette lighter adapter
TEFTYG	Teflon-lined Tygon [®] tubing
SILTUB	Silicone tubing
OZSOURCE	Ozone source with power supply
NDLVLV	Needle Valve